

redcare

Redcare Secure

Installation, Maintenance and Operational Manual

Model
UC-351 GP/E-UK

Information for installers

redcare

TABLE OF CONTENTS

1	INTRODUCTION	3
2	PARTS LIST	5
3	SAFETY WARNINGS AND OPERATING CONDITIONS	6
4	MOUNTING AND WIRING	8
5	PIN POLARITY LEARNING	15
6	CONFIGURING THE REDCARE SECURE UNIT	16
7	NETWORK REGISTRATION AND COMMISSIONING.....	23
8	MAINTENANCE AND OPERATIONS	32
9.	SUPPORT CONTACT DETAILS	34
APPENDIX A	INSTALLATION CHECKLIST	35
APPENDIX B	BT REDCARE SECURE UNIT GENERATED EVENTS.....	36
APPENDIX C	TROUBLE SHOOTING	37
APPENDIX D	DTMF CONFIGURATION CODES	38
APPENDIX E	SECURE IP (GRADE 4 ONLY) SPECIFICATION NOTES.....	40
APPENDIX F	DISPOSAL	41
APPENDIX G	ABBREVIATIONS	42
APPENDIX H	REGULATORY APPROVALS.....	44

1 Introduction

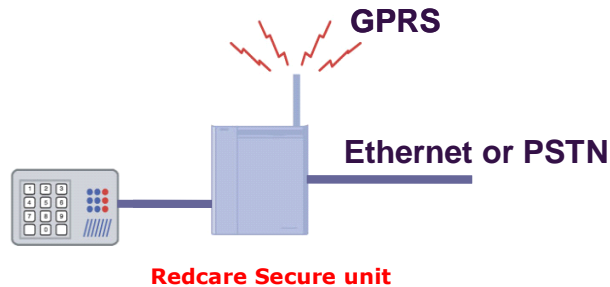

Figure 1 – Redcare Secure Security Communicator

The Redcare Secure unit is a multi-function security communicator from BT Redcare. It combines:

- Alarm panel dial capture unit
- Cellular (GSM-GPRS) modem
- 0800 PSTN (IP) uplink
- Ethernet (IP) uplink
- General-purpose alarm and status inputs and outputs

Typical applications include:

- Commercial / Residential alarm systems (Signalling grades 2, 3 or 4)
- Fire alarm systems
- Consumer alarm systems that require dual path delivery

The Redcare Secure unit can be used in any one of the following configurations. (Redcare ESP dependant)

Secure 2 Grade 2 - Primary path GPRS, Secondary path PSTN (Voltage monitored with 1008 hour heartbeat, 24 hour PSTN call on GPRS Fail)

Secure 3 Grade 3 - Primary path GPRS, Secondary path PSTN (Voltage monitored with 1008 hour heartbeat, 4 hour PSTN call on GPRS Fail)

Secure IP Grade 4 - Primary path IP, secondary path GPRS.

PRODUCT	SECURE 2	SECURE 3	SECURE IP
Both paths working, PSTN/IP path fails – fault reported in	2 MINS	2 MINS	70 SECONDS
Both paths working, Radio path fails – fault reported in	5-55 MINS	5-55 MINS	3-13 MINS
Only Radio path working and it fails – fault reported in	55 MINS	55 MINS	70 SECONDS
Only PSTN/IP path working and it fails – fault reported in	25 HOURS	5 HOURS	70 SECONDS
If both paths failed simultaneously – fault reported in	55 MINS	55 MINS	13 MINS
Primary Polling Frequency	5 MINS	5 MINS	10 SECONDS
EN GRADE	2	3	4
ATS VALUE PRIMARY	ATS4	ATS4	ATS5
ATS VALUE SECONDARY	ATS3	ATS4	ATS4

Figure 2 - Polling rates and communication fail alarm transmission times

Note: The polling rates and communication fail alarm transmission times in Fig 2 may be liable to change. For the latest information, refer to the Technical information sheet at http://www.redcare.bt.com/partner/brochure_list.htm

Note: Where the Redcare Secure unit is connected to a PSTN line (Secure 2 & 3) then the line should be either a dedicated line, or a line of low usage, to ensure that the necessary out going test calls and alarm calls can be made when required.

2 Parts List

The Redcare Secure Unit is shipped with the following items:

- Redcare Secure unit (**Blue PCB**)
- Adhesive pads
- Antenna
- SIM card (fitted)

The following are required in order to complete the Redcare Secure installation:

General hand tools (2mm blade screwdriver, wire cutters, etc)

Connection cable

ADSL filter (Secure 2&3 only) for PSTN broadband lines

3 Safety Warnings and Operating Conditions

Qualified Personnel Only

Only qualified service personnel should install, and perform subsequent maintenance on the Redcare Secure Unit.

Battery Handling

Take care not to short the battery in the host alarm system. A short-circuited battery can deliver large currents that could result in serious burns or create a fire hazard. Dispose of used batteries according to local environmental regulations.

Power Requirements

Voltage: 9VDC to 30VDC *

Current: @ 13.8V:

- Pin only mode 230mA quiescent, 280mA peak alarm transmission.
- Dial capture mode (SIA / CID / FF) 270mA quiescent, 450mA peak alarm transmission.

Current: @ 24V = 170mA

Ripple/noise: 200mVpp max.

Low battery threshold: 10.2V +/- 0.5V.

** The Secure unit can be used with 24V volt systems, i.e Fire Alarm panels, but be aware that the low voltage threshold alarm is fixed at 10.2V.*

Pin Alarm Inputs

Logic High = +3.5V to +30V

Logic Low = -0.5V to +0.8V

General Purpose Outputs: (on J1400)

Logic High = 12V (nominal) @ 1mA max

Logic Low = 0.4V @ 200mA max

These voltages are with respect to the 0V terminal on the Power Connector J800.

Physical Dimensions

Size = 168 x 115 x 36 mm

Mass = 500 g

SELV Connectors

Connectors J1300, J1301 (pin inputs) J1400 (outputs), J1000 (alarm panel), J600 (Ethernet) and J 800 (DC power) have been classified as SELV and must only be connected to approved SELV circuits. If the circuit to be connected to these terminals is not SELV an isolation unit compliant

with local market regulatory requirements must be used. SELV circuits are determined in IEC60950 and equivalent national standards.

Operating Conditions

The Redcare Secure unit is rated to operate under the following conditions:

- Indoor operation
- Ambient temperature: -5°C (23°F) to +55°C (131°F)
- Humidity: 5% to 95%

Note: It is recommended to use a power supply capable of providing at least 450mA at 13.8VDC for this product.

4 Mounting and Wiring

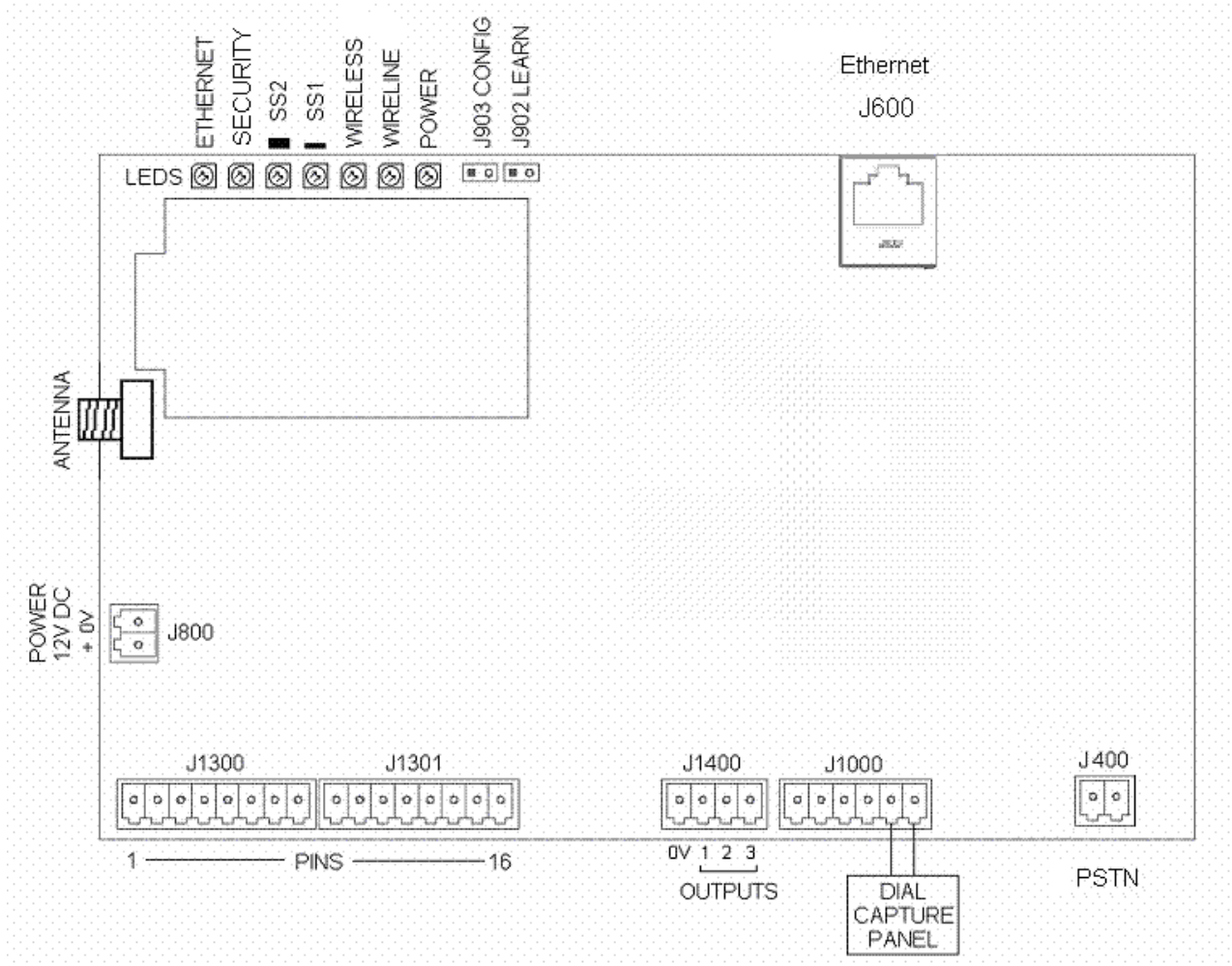

Figure 3 - Redcare Secure unit connections

Redcare Secure LED functions:

- Power** - Supply voltage indicator
- Wireline** - Wireline (PSTN or Ethernet) status indicator
- Wireless** - GPRS status indicator
- SS1, SS2** - Wireless Signal Strength indicators
- Security** - 1 blink = new input event detected
- Ethernet** - Data present on RJ45

Selecting the Mounting Location

When surveying the site, please remember that the Redcare Secure unit operates in a similar way to an ordinary mobile telephone. Therefore any restrictions on the use of mobile telephones in the area will also apply to the Redcare Secure unit.

Premises such as hospitals, petrol stations, airports, blasting areas etc may operate a mobile telephone restriction in certain areas. Always ensure that the chosen site is free of any mobile telephone restrictions and advise the end user so that they are aware, should any restrictions come into force in the future.

If possible, perform a signal strength test during a pre-installation site visit. To perform a GSM signal strength test:

1. Determine where the Redcare Secure unit will be situated
2. Place the test mobile phone where the Redcare Secure unit is to be installed, Switch it on and observe the signal strength from the appropriate mobile network.

If the signal strength is weak, try to find a better position for the Redcare Secure unit. If required, extension antennas and extension cables are available. Please contact **08702 400503** for further advice.

Install away from any other Radio sources. Keep at least a 3 metre separation.

Mounting the Redcare Secure unit

Important: Ensure the alarm system is powered down (switch off mains and disconnect the battery) before installation can commence.

Ensure that the base of the Redcare Secure unit is free from dust or grease. Use the supplied double sided mounting pads to fit the Redcare Secure unit onto a clean, flat surface within the host enclosure, or in its own tamper-protected box.

PSTN connection (Secure 2 & Secure 3 / Grade 2 & 3 only)

Connect 2 wires A & B from a suitable PSTN telephone line to J400. Line polarity is not important.

Ethernet Connection. (Secure IP / Grade 4 only)

Run an Ethernet cable from a convenient network connection to the Redcare Secure unit's Ethernet connector, J600.

The Ethernet port auto-senses, so that either a straight-through or cross-over Ethernet cable can be used.

Only ready-made, certified cables should be used when connecting the redcare Secure unit to network equipment. If cabling has to be made on site then testing and certification to EN 50173 Class D should be performed. Failure to use certified network cabling can lead to intermittent and spurious faults that are difficult to trace without specialist equipment.



J600

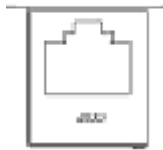

Figure 4 - J600 Ethernet connection

Power Connection

Ensure power is off when cabling the power connectors.

The power connection is via terminal J800.

Connect the +12V or +24V to the terminal labelled + of J800, and 0V to the terminal labelled 0V of J800.

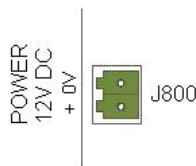

Figure 5 - J800 power connection

The power wiring must be less than 3m in length and use wires having core areas of at least 0.5mm².

Tamper

If an additional tamper connection is required, connect the tamper switch to GPIB 12.

Antenna

The antenna provided is a flat type and must be mounted indoors, on a flat horizontal surface, sufficiently close that it can be connected to the Redcare Secure unit. The antenna is self-adhesive and will bond firmly to any clean, dry and flat surface. Make a suitable hole, (typically 11mm diameter) in the top of the box in which the Redcare Secure unit is fitted. Prevent swarf from entering the enclosure as it could cause internal short circuits.

Remove any burrs from the hole, pass the RF cable through it and place the antenna in position.

Do not permanently fix the antenna until a Signal Strength Test has been performed.

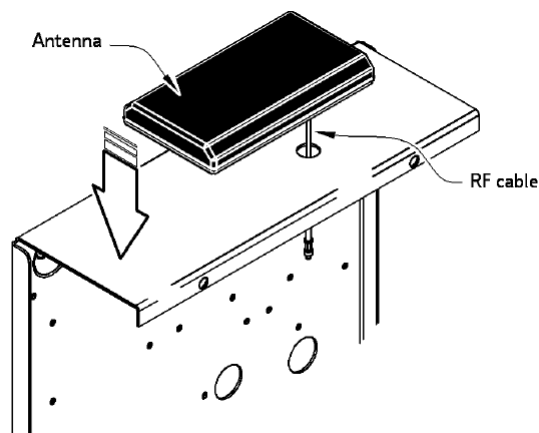

Figure 6 - Antenna position

Extension Antenna

An extension antenna can be used in the event that the Receive Signal strength at the location is inadequate, and changing locations is not an option. Two high gain antennas are available:

1. Aerial (short) – AO100 External base antenna
2. Aerial (long) – BA900-5 High gain antenna (1.2m white stick)

Each antenna is supplied with a 5 m RG 58 coaxial cable terminated by a female FME connector. A 20 cm male FME to male MMCX flying lead is used to terminate the antenna on the Redcare Secure unit GSM module.

A 10 m low-loss URM 76 coaxial cable is available should the cable run to the antenna need to be extended. This cable is equipped with a male FME connector at one end and a female at the other.

Alarm Panel Connection – Pins

To interface to a panel with pin alarms, connect the alarm panel outputs to the alarm input terminals on J1300 and J1301.

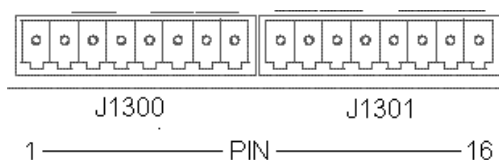

Figure 7 - General Purpose Input Pins

Unused input terminals can be left unconnected.

The following General Purpose inputs (GPIP's) have specific purposes:

- GPIP4** Will raise a Pin 4 alarm and trigger the RPS function on output pin 3.
- GPIP11** When configured for BSIA Form 175 functionality, activates a response on output 1 (GPOP1) to interrogate local path fault, or raises a BSIA Form 175 Test alarm over each signalling path.
- GPIP12** Will raise a Pin 12 alarm for general use. Typically mapped as a tamper alarm at ARC.
- GPIP13** Dedicated for AC fail indication, will raise a Pin 13 alarm after a delay of 7 minutes.

Alarm Panel Connection – Dial Capture

To use dial-capture, connect the alarm panels digicom line connectors to the Redcare Secure's Alarm Panel interface J1000.

Pins 1, 2 - Alarm Panel In

Pins 3, 4 - Unused

Pins 5, 6 - Unused

The diagram below shows the alarm panel connection.

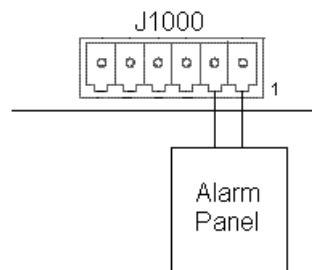

Figure 8 - J1000 Alarm Panel connection

Note: When using the alarm panel interface port to connect to the Redcare Secure unit, there will be a delay between the alarm panel activating the dialler notification output and the Redcare Secure sending the message to the ARC. The length of the delay may be up to 20 seconds and varies depending on the make and model of the alarm panel. Also, if the panel goes off-hook but fails to dial within 10 seconds, a "Panel Dial fail" alarm will be sent.

General Purpose Outputs (GPOP's)

Three General Purpose outputs are provided. The outputs are open collector outputs (with 12V pull-up). The outputs are rated to 30V.

The outputs are wired to J1400 as shown.

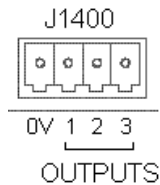

Figure 9 - J1400 General Purpose Output Pins

By default, the General Purpose outputs (GPOP's) have the following specific purposes:

GPOP1: Local path fault output (BSIA Form 175 mode)

GPOP2: ARC controlled output

GPOP3: Return path signalling (RPS) output (in conjunction with input pin 4)

WARNING

Connectors J600, J800, J1000, J1300, J1301 and J1400 have been classified as SELV and shall only be connected to approved SELV circuits. If the circuit to be connected to these terminals is not SELV, a regulatory authority compliant isolation unit must be used. SELV circuits are determined in IEC60950.

For basic installations the wiring of GPOP's is not required.

Where local comms fail reporting is required in compliance with BSIA form 175 then make the following connections.

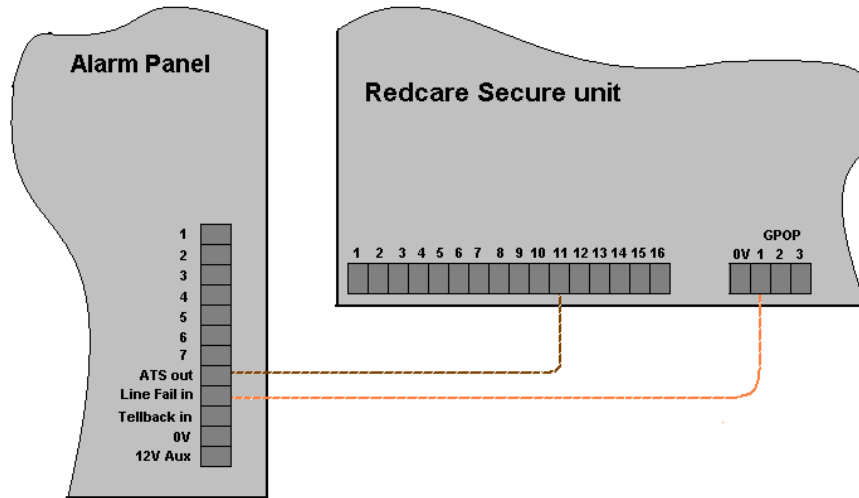

BSIA Form 175 wiring ensures panel detects Single / Dual path failure

5 Pin Polarity Learning

The Redcare Secure unit can be forced to learn the polarity of the pin alarm inputs as follows.

1. Short out the Learn header J902 with a link.
2. Power up or power-cycle the unit.
3. Wait around 15 seconds until the LED's flash in the "learn ready" pattern (left to right scrolling pattern).
4. Connect all 16 pin inputs in the Normal state (including input 4 as closed state).

Note: If pin 12 is used for Tamper it must also be connected in its normal (closed) state, even though the enclosure may actually be open

5. Remove the header from J902. The unit will briefly flash all LED's off-on-off to indicate learning has completed and will store this information in non-volatile memory.

The boot sequence will then continue.

Note: If the polarity of a pin (or pins) needs to be changed, the above procedure should be repeated, with the relevant pins connected in the Altered State at stage 4.

6 Configuring the Redcare Secure unit

The unit is supplied pre configured for pin only input mode and PSTN working. (Secure 2 / Secure 3)

For most installations no further configuration will be required.

For alternative installation requirements the following configuration options are available.

There are two methods available to configure the unit. It can be configured with either a DTMF phone **or** through a web console on a PC internet browser.

Configuration Method 1. Configuring with a DTMF Phone

1. Prepare wiring as described in Section 4.
2. For initial power-up and configuration, the following minimum connections are required:
 - a. DC Power
 - b. Antenna (for wireless operation)
3. Connect a DTMF phone to the units's alarm panel port J1000. An adapter is available from Redcare. See fig 10
4. Short out the Config header J903 with a link.
5. Power up or power-cycle the unit.
6. Around 15 seconds after power on, the six rightmost LED's will flash providing a period of 20 seconds to lift the telephone receiver, receive dial tone and press the '#' key to enter configuration Mode.

Note: Configuration Mode is terminated after five minutes, or when the installer hangs-up the DTMF phone.

Note: If the Config header is left shorted once configuration mode is completed the unit will not dialup or communicate at all.



Figure 10 – Adapter to connect a DTMF telephone to J1000 for configuration.

Configuring Panel Format

By default the unit is configured for pin-only mode. This mode disables the dial capture port to reduce power consumption. Use the following command to enable the dial capture port and set it to receive the relevant panel format where dial capture is required. Note Pins can still be reported in any of these other modes.

To change the panel format, use the * 15 * option:

- * 15 * 1 # ContactID
- * 15 * 10 # High Speed (fast format)
- * 15 * 20 # SIA
- * 15 * 30 # Pin Only mode - **default**

The Redcare Secure unit supports several other less common formats listed below:

- * 15 * 2 # ContactID with Double Knock
- * 15 * 3 # 4 + 1 express (DTMF mode only)
- * 15 * 5 # 4 + 2 express (DTMF mode only)
- * 15 * 11 # High Speed with Double Knock
- * 15 * 21 # SIA with V21 tones

If no more parameters are to be configured, remove the header from J903 and disconnect the DTMF phone.

Configuring General Purpose Outputs

By default, the Redcare Secure unit's General Purpose Outputs (GPOP's) operate as follows:

Output	Default Function	Default Polarity
GPOP1	Local path fail output	High to indicate either path failure. (BSIA 175 mode)
GPOP2	Remotely (ARC) Controlled	0 from ARC sets output High, 1 from ARC sets output Low
GPOP3	RPS function (in conjunction with input pin 4)	Alarm sent sets output High, Alarm ack'd sets output Low

Figure 11 - General Purpose Output Pin operations

The following commands can be used to configure the behaviour of the GP Outputs:

GPOP1

- * 91 * 20 BSIA Form 175 Mode – **default mode**
- * 91 * 30 Standard Path Fail Mode Active Low (Failure of any communications path causes a Low on GPOP1)
- * 91 * 31 Standard Path Fail Mode Active High (Failure of any communications path causes a High on GPOP1)
- * 91 * 50 Standard Path Fail Mode 2 Active Low (Failure of both communications paths causes a Low on GPOP1)
- * 91 * 51 Standard Path Fail Mode 2 Active High (Failure of both communications paths causes a High on GPOP1)

GPOP2

- * 92 * 10 Remotely (ARC) Controlled Active Low (0 from ARC sets output High, 1 from ARC sets output Low) – **default mode**
- * 92 * 11 Remotely (ARC) Controlled Active High (1 from ARC sets output High, 0 from ARC sets output Low)

GPOP3

- * 93 * 10 RPS function Active Low (Alarm sent on GPIP4 sets output Low, Alarm acknowledged sets output High)
- * 93 * 11 RPS function (Alarm sent on GPIP4 sets output High, Alarm acknowledged sets output Low) – **default mode**

Note: GPOP3 is used, in conjunction with GPIP4, for Return Path Signalling (RPS). On receiving an indication on GPIP4 (i.e. an opening or closing signal), the unit sets GPOP3. On receiving the ACK from the ESP, the unit clears GPOP3.

If no more parameters are to be configured, remove the header from J903 and disconnect the DTMF phone.

Configuring PSTN Pre-Dial String

The unit is default configured with a pre-dial string of **1470** to provide CLI. If a pre-dial string is present, a 1 second pause is automatically added before the main phone number. Additional pauses may be added within the dial string using ***0**, an asterisk may be added using ***1**, and a hash may be added using ***2**

Examples of some Pre-dial configurations.

*50*9# (Featureline or CLI enabled PABX line)
*50*91470# (For a silent PABX line)
*50*9*01470# (For a silent PABX line with pause)
*50*1470# (default setting)
50# (Clear predial string)

Configuring the Account Number / TAID (Optional)

The Redcare Secure unit does not require its Account Number TA ID to be entered for normal operation, but it can be configured with the following command to aid identification where necessary.

To set the Account Number / TA ID

* 20 * TAID # Check Digit

Example * 20 * 4191000 # 1

The unit sends a soft acceptance tone after each '#' and after the Check Digit. A series of sharp beeps means data has been incorrectly entered. Re-enter the full command.

If no more parameters are to be configured, remove the header from J903 and disconnect the DTMF phone.

Configuration Method 2. Configuration with a Web Browser

The Redcare Secure unit's management console is available at <http://192.168.222.222/>, only when the Configuration header, J903, is shorted. If it is not possible to connect using the Username and Password supplied during training, please contact the Redcare Helpline (see Section 8).

Note that the unit does not run a DHCP server, so you must configure the PC with a static address on the same subnet as the unit. For example, configuring the PC to have IP address 192.168.222.10 would allow connection to the unit.

Once connected, surf to the Quick Start link (see *Figure 9*). From here the following parameters can be configured:

Interface combination select GP Wireless / Dial UP for Secure 2&3, or select GE Wireline / Wireless for Secure IP (grade 4)



Panel Type This is the alarm panel protocol. This must match the protocol configured in the alarm panel if connected to a dialler alarm panel through the dial capture port.

Line voltage monitoring. Enable / Disable the unit's PSTN voltage detection circuitry. (Secure 2&3 only – Line voltage monitoring is used to signal pin 955 alarms and to detect when the line is in use by another telephone)

Line voltage alarm delay. Time to signal a PSTN Voltage Failure alarm (pin 955). Default 120 seconds. (Secure 2&3 only). Also applies to GPOP1

Line voltage restore delay. Time to signal a PSTN Voltage Failure restore (pin 955). Default 30 seconds. (Secure 2&3 only). Also applies to GPOP1

Line in use (LIU) Indicator. Enable / Disable the PSTN voice detection circuitry within the unit's PSTN modem (Secure 2&3 only – LIU is used to detect when the PSTN line is in use by another telephone. If Line Voltage monitoring is enabled this setting is ignored)

Output Settings including the definition of the operation and polarity of the General Purpose Outputs (1-3). (Default BSIA form 175 mode)

Line Fault Debounce time (Mins). Set the delay before GPOP1 state changes. t1,t2,t3,t4,t5,t6. Where t1=IP fail delay, t2=IP restore delay, t3=GPRS fail delay, t4=GPRS restore delay, t5=PSTN dial fail delay, t6=PSTN dial restore delay. Default 2,0,15,0,15,0 (S/W Version >52 only)

Account Nbr / TA ID This number can be used to identify the site. (optional)

IP Settings including DHCP Client or static local IP and gateway addresses (Secure IP only).

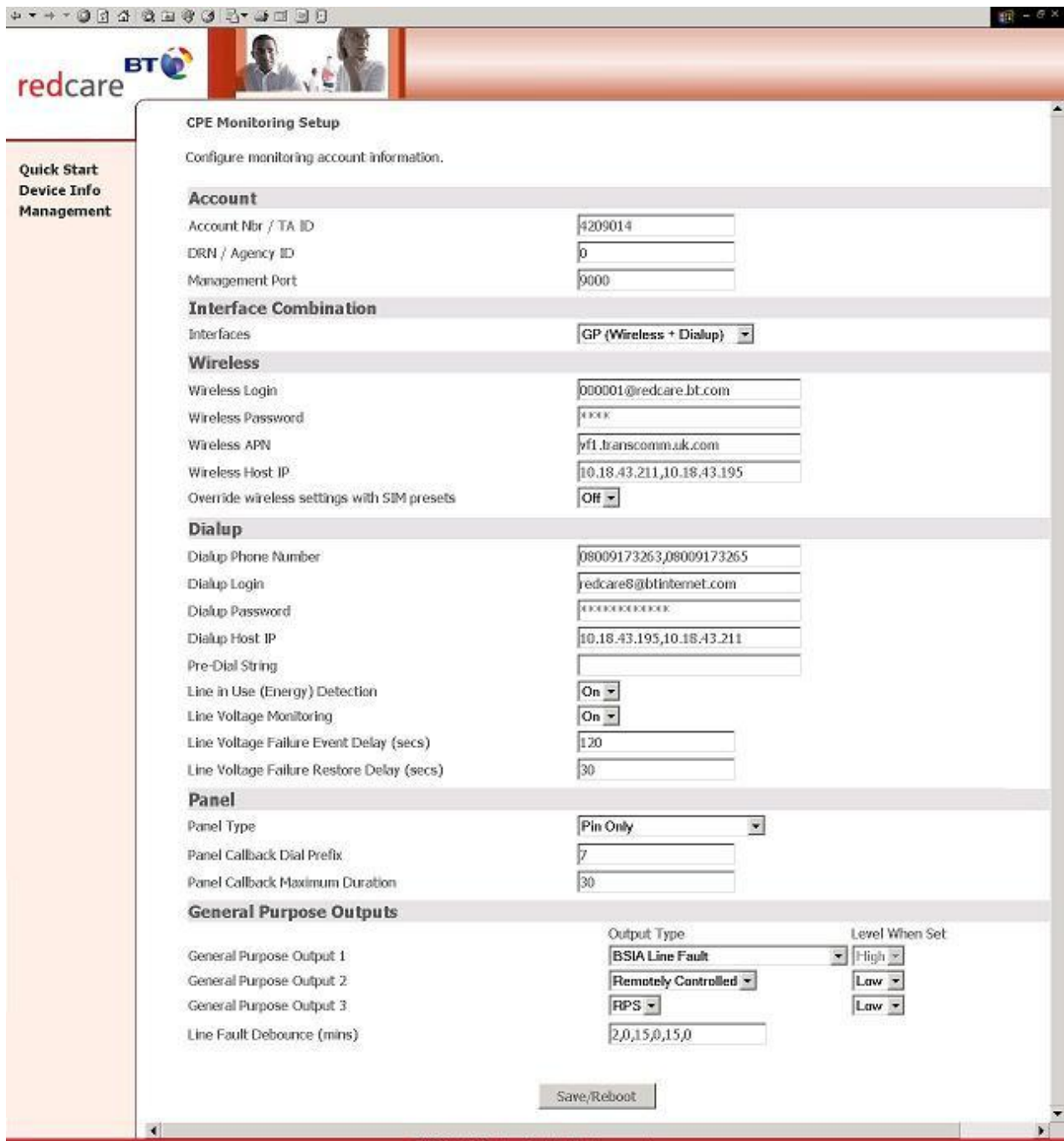

Figure 12 - Screenshot of the Quick Start Menu when set for PSTN working

On completion of the configuration, click the **“Save/Reboot”** button at the bottom of the screen and remove the header from J903. Wait 1 minute for the save re-boot process to complete.

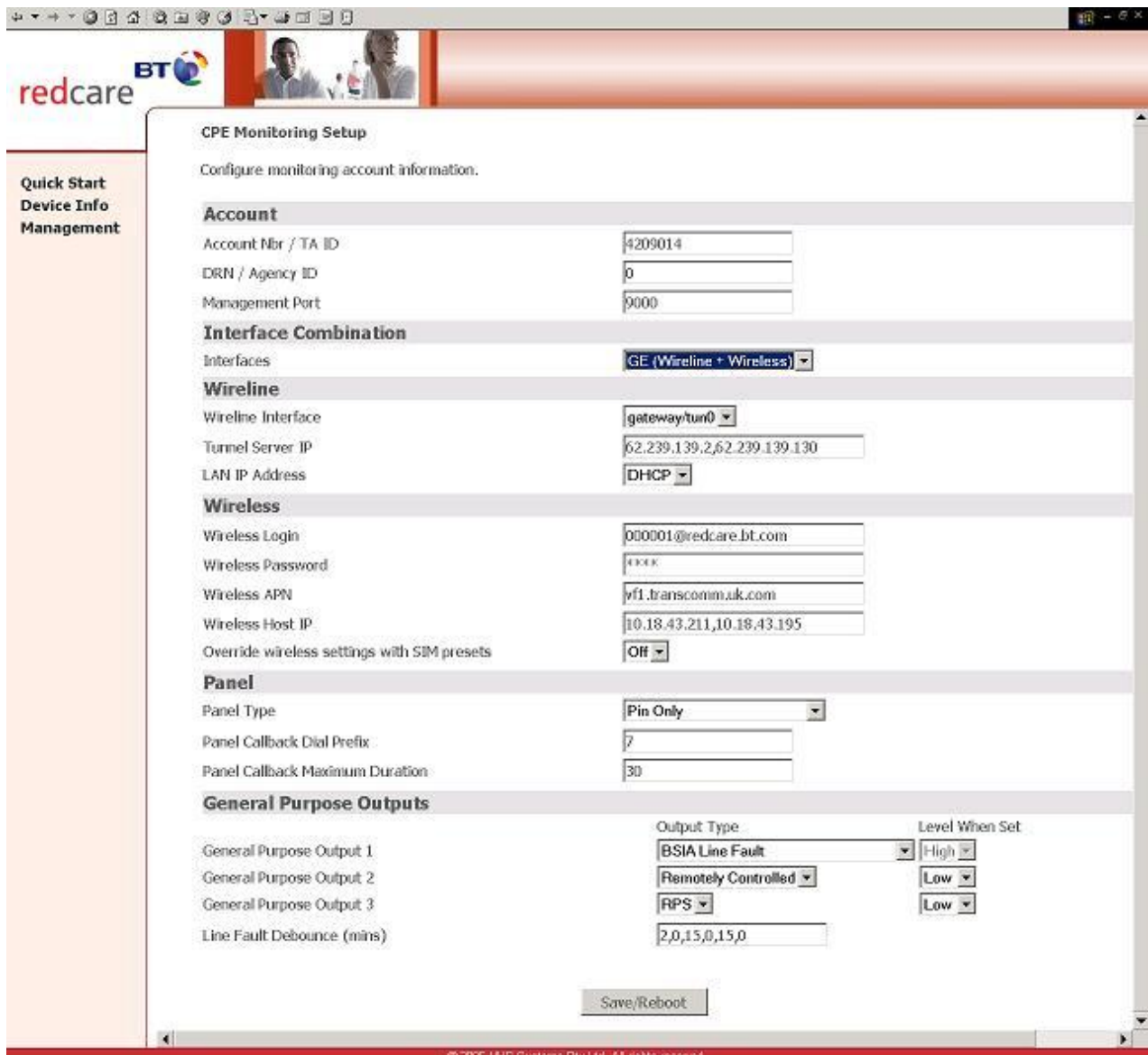

Figure 13 -. Screenshot of the Quick Start menu when set for IP working.

7 Network Registration and Commissioning

Ensure both Config and learn headers are removed.

If Config Header (J903) is shorted, the unit will not attempt to register on the Redcare Enterprise Service Platform (ESP). The header short should be removed once configuration is complete.

Network Registration

On startup, the unit will immediately attempt to register on the Redcare ESP with all available interfaces:

- GPRS
- PSTN or Ethernet

During registration and also in normal operation, the meaning of the LED indications is as follows:

State	Wireline (LED 2)	Wireless (LED 3)
Off	Either: The unit is in the process of starting up or: The wireline path is not available. i.e. Ethernet port cannot obtain an IP address or PSTN path was unable to complete the last dial up attempt)	Either: The unit is attempting to obtain an IP address or: The wireless interface is not available
Slow Flash 1s Off 1s On	The Unit is attempting to set up an IP path to the ESP. (i.e. Ethernet port has obtained an IP address and is attempting to reach the ESP. Or PSTN is attempting to establish a dial up call)	The unit has an IP address over its wireless (i.e. GPRS) interface and is attempting to contact the ESP
Fast Flash 250ms Off 250ms On	PSTN path has a call in progress and is communicating with the ESP	N/A
Blink 50ms On 950ms Off	PSTN path has detected PSTN voltage fail < 1.5V on PSTN	N/A
On	The unit is connected to the Redcare ESP via IP, or the last PSTN dial up call was successful.	The unit is connected to the Redcare ESP via GPRS

Figure 14 - Wireline and Wireless LED indications



If either the Wireline or Wireless network connection is available (i.e. respective LED is flashing slowly), but does not become solid or fast flashing for 30 seconds, then the unit is not registering with the Redcare ESP. This could be due to an error in activation. Contact the Redcare Helpline for assistance.

Signal Strength Test

LEDs SS1 and SS2 provide a signal strength indication. Signal strength is indicated as shown in Figure 15

SS2	SS1	Signal Strength	Quality
Off	Off	No reading available (e.g. modem is being reset or attempting to register) or <-89dBm	Unacceptable
Off	FLASH	-89dBm to -83dBm	Boarderline
Off	On	-83dBm to -77dbm	Good
FLASH	On	-77dBm to -69dBm	Very Good
On	On	> -69dBm	Excellent

Figure 15 - Signal Strength LED indications

Commissioning

Once the unit is registered with the Redcare ESP, perform the following steps:

1. Ensure the unit is connected to the network.
2. Power cycle the unit to begin the commissioning process (both headers off).
3. After 1 minute the unit will begin establishing its communication paths.
4. After a further 1 minute, LEDs 2 & 3 should be permanently lit to show that the Wireline & Wireless paths are both available. Note that the rightmost LED (Power indicator) is LED 1.

Time hh:mm:ss	Path Indicator	Pin	CID (zone)	SIA (zone)	Description
10:00:00	0x13	1023;0	R350 (999)	NR (999)	Wireline Path communications restore
10:00:03	0x13 or 23	984;1	E305 (995)	AT (995)	Unit restarted (power up cycle) event
10:00:04	0x13 or 23	984;3	R305 (995)	AR (995)	Unit restarted (power up cycle) restore
10:00:11	0x23	1022;0	R350 (998)	NR (998)	Wireless Path communications restore

Figure 16 – Typical ARC alarm log for Redcare Secure unit initial commission

Note that the unit sends a “Unit Restart” alarm / Restore cycle over the first available interface if the power to the unit has been interrupted.

(0x13 indicates Wireline path, 0x23 indicates Wireless path).

Test alarms can now be generated.

If the unit is configured for BSIA 175 working, briefly apply an alarm condition to pin input 11. Within 1 minute a pin 988 event & restore should be received at the ARC over both paths. This test proves that both paths are signalling correctly. Note that if both paths are not available, no alarm will be received by the ARC.

Time hh:mm:ss	Path Indicator	Pin	CID (zone)	SIA (zone)	Description
10:05:00	0x13	988;1	E354 (997)	TX (999)	BSIA 175 IP Test message event (IP)
10:05:02	0x23	988;1	E354 (997)	TX (998)	BSIA 175 GPRS Test message event (GPRS)
10:05:02	0x13	988;3	R354 (997)	TE (999)	BSIA 175 IP Test message restore (IP)
10:05:03	0x23	988;3	R354 (997)	TE (998)	BSIA 175 GPRS Test message restore (GPRS)

Figure 17 - Typical ARC alarm log for Redcare Secure unit BSIA Form 175 path test

Apply an alarm / restore condition to all used input pins.
 These events will be signalled immediately over GPRS path if available.

Time hh:mm:ss	Path Indicator	Pin	CID (zone)	SIA (zone)	Description
10:07:00	0x13 or 0x23	4;3	R323 (904)	UR (904)	Pin 4 Close (panel set)
10:08:00	0x13 or 0x23	2;1	E323 (902)	UA (902)	Pin 2 panic alarm event
10:09:00	0x13 or 0x23	3;1	E323 (903)	UA (903)	Pin 3 intruder alarm event
10:09:30	0x13 or 0x23	7;1	E323 (907)	UA (907)	Pin 7 confirmed intruder alarm event
10:10:00	0x13 or 0x23	4;1	E323 (904)	UA (904)	Pin 4 Open (panel unset)
10:10:02	0x13 or 0x23	2;3	R323 (902)	UR (902)	Pin 2 panic alarm restore
10:10:03	0x13 or 0x23	3;3	R323 (903)	UR (903)	Pin 3 intruder alarm restore
10:10:04	0x13 or 0x23	7;3	R323 (907)	UR (907)	Pin 7 confirmed intruder alarm restore
10:15:00	0x13 or 0x23	12;1	E323 (912)	BA (912)	Pin 12 Tamper alarm
10:15:10	0x13 or 0x23	12;3	R323 (912)	BR (912)	Pin 12 Tamper alarm restore

Figure 18 - Typical ARC alarm log for Redcare Secure unit test pin alarms during commissioning

Check with the ARC that these alarms have been received over the relevant paths.

Remote trigger of dual path test

The ARC can send the telemetry command ID=01, Data=00 to cause the Redcare Secure unit to send a BSIA test message on all available paths. Within 70 seconds a pin 988 Event / Restore will be received via each path.

Dial Capture test

If the alarm panel is connected to the Dial Capture port of the unit, generate panel test alarms / restores and confirm that they are received at ARC.

Time hh:mm:ss	Path Indicator	CID (zone)	SIA (zone)	Description
10:20:00	0x13 or 0x23	R401 (001)	CL (001)	Panel Close (panel set)
10:21:00	0x13 or 0x23	E120 (001)	HA (001)	Panic alarm event
10:22:00	0x13 or 0x23	E130 (002)	BA (002)	Intruder alarm event
10:22:30	0x13 or 0x23	E139 (001)	BV (001)	Confirmed intruder alarm event
10:23:00	0x13 or 0x23	E401 (001)	OP (001)	Panel Open (panel unset)
10:23:02	0x13 or 0x23	R305 (000)	OR (000)	System Reset (panel reset)

Figure 18 - Typical ARC alarm log for Redcare Secure dial capture alarms during commissioning

Actual alarms will be dependant on panel type and protocol.

If the ARC receives a Bad Panel Checksum Error, the panel is not transmitting in a format known to the Redcare Secure unit

If the ARC receives a Panel Type Mismatch Error, the Redcare secure unit is not configured for the correct panel format.

Communication fault testing

Disconnect the wireline path connection and confirm that the correct alarm is received at the ARC

Secure 2 & 3	Pin 955 after 120 seconds, Restore after 30 seconds
Secure IP	Pin 1023 after <60 seconds, restore after < 60 seconds

Notes

- A PSTN voltage fail alarm (955) will be generated by the unit, and generally signalled over the GPRS path, if the PSTN voltage stays below 1.5V for 120s. A restore will be signalled after 30s of the PSTN voltage returning to normal. (Default settings)
- The transmission path of messages can be identified at the ARC by looking at the receiver number, generally within the raw message data. (13 = Wireline, 23 = GPRS).
- As a general rule, messages signalled on zones >900 are Redcare Secure unit generated events, whereas messages signalled on zones <900 are panel generated events.



Configuring the panel to communicate with the redcare Secure dial capture port

If the alarm panel is being connected to the unit using the Dial Capture port, then the following configuration should be entered into the alarm panel:

Call mode	Single telephone number reporting
Reporting format	CID / SIA / FF to match Redcare Secure units configuration
Dialler Receiver number	29
Account Number	Last 4 or 6 digits of Secure unit TAID
Static test call	Daily

Figure 19 - Alarm Panel configuration settings

Remote panel access

The Redcare Secure unit offers 3 methods of obtaining remote access to an associated alarm panel, for the purpose of carrying out remote maintenance.

Method 1 – Panel Dial out over PSTN.

If the unit is being used with CID, SIA or FF panel format through the Dial Capture port, and a PSTN line is connected to J400, then prefixing the panels downloader telephone number with 7 will operate the unit's bypass relay and allow the panel to dial out to a remote alarm installer's PC modem. Remote panel downloader access can then be carried out. The bypass relay will reset when the alarm panel drops the PSTN connection or if 30 minutes has elapsed. A pin 993 event will be reported when the redcare Secure unit's bypass relay operates, and a pin 993 restore will be reported when the bypass relay releases.

Method 2 – PSTN dial in to panel.

If the unit is being used with CID, SIA or FF panel format through the Dial Capture port, and a PSTN line is connected to J400, then the following method can be used for remote dial in panel access to the alarm panel. Contact the ARC and request them to operate the Redcare Secure units's bypass relay. An incoming PSTN call will then be routed through the unit's bypass relay and on to the alarm panel. A panel download, pin 993, event will be reported to the ARC at the time that the bypass relay operates. The unit's Bypass relay will remain operated for a maximum of 1 hour, or until a "switch to On-line mode" command is sent from the ARC.

The ARC gateway telemetry commands to remotely operate the bypass relay are:

ID=01, Data=02 to switch to bypass mode

ID=00, Data=02 to switch to online mode

Method 3 – Over the Air dial in.

Redcare Secure units with Version P60 software and above will also allow Over the Air (OTA) panel remote access whereby a downloader link can be set up across the unit's GPRS path. Refer to the Redcare Secure OTA Supplement document for further details.

Connecting alarm pin inputs

For alarm panels that provide 'Positive applied' or 'Positive removed' communicator outputs, the unit's input pins can be wired directly to the Alarm panel.

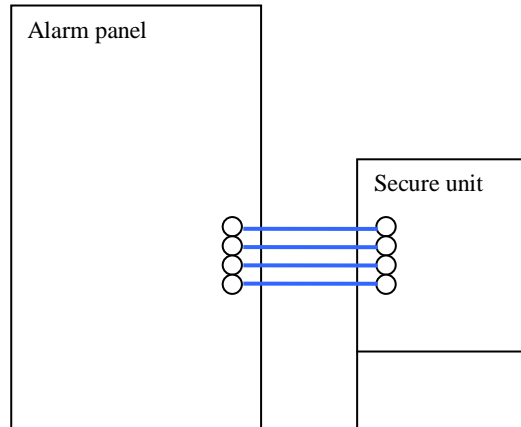

Figure 20 - Alarm panel with Positive Applied or Removed communicator outputs

For alarm panels that have open collector communicator outputs (sometimes referred to as 'Negative Applied' outputs) an additional 10K pull-up resistor will be required to be connected for each input pin.

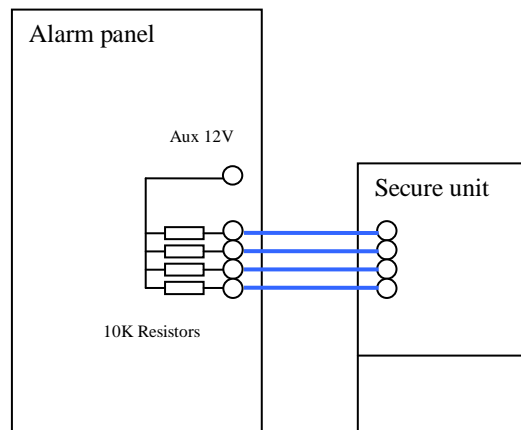

Figure 21 - Alarm panel with Open collector (Negative applied) communicator outputs with an additional 10K pull up resistor for each pin

Note: Ensure the 0V of the alarm panel is Commoned to the 0V of the Redcare Secure unit when separate Power Supply Units are used.

8 Maintenance and Operations

The Redcare Secure product is managed by the ESP servers, and appropriate alarms are raised to alert the ARC to faults (see appendix B). This section describes the operational and maintenance activities that may be required.

Internal Access

The Redcare Secure unit is usually installed in a tamper monitored alarm system, so in general it is necessary to authorise yourself with the monitoring ARC before opening the unit. Once you have alerted the ARC:

1. Remove all watches, rings or other metal objects from your hands.
2. Use ESD protection.

Unit Replacement

To replace the unit, perform the following actions:

1. Switch off and disconnect the mains supply of the host alarm system.
2. Remove all watches, rings or other metal objects before opening the lid.
3. Disconnect and remove the battery of the host alarm system.
4. Mount the replacement unit and replace cable as per Section 4.
5. Reconnect the mains supply and switch on.
6. Contact the Redcare Helpline. The new unit serial number (SID) will need to be entered into the ESP by Redcare staff, to bring the new unit back into service.

If a unit is being changed out for a SIM-less maintenance spare, then the SIM card must be removed from the failed unit and inserted into the replacement unit. Carry out this procedure as follows.

1. Power down the failed unit
2. Remove the 3 screws that secure the PCB to its plastic.
3. Remove the PCB
4. Remove the SIM card from the holder on the underside of the PCB
5. Write down the 20 digit SIM number as printed on the SIM card
6. Insert this SIM card into the holder on the replacement unit.
7. Connect up the replacement unit
8. Contact the Redcare Helpdesk and quote them the TA ID, Unit Serial Number (SID) and SIM number.

9. Support Contact Details

For assistance with your Redcare Secure installation,
Contact the Redcare Helpdesk on **0800 671 240** option 5

Appendix A Installation Checklist

Before leaving the premises, complete the following Installation Checklist.

- Redcare Secure unit securely mounted in host alarm system.
- Redcare Secure unit powered up.
- Tamper connection wired if required.
- Configuration and learn link headers removed.
- Wireless signal strength is acceptable.
- Redcare Secure unit communicating with Redcare ESP over Wireless interface.
- Redcare Secure unit communicating with the Redcare ESP over Wireline path.
- Alarm panel connected to Redcare Secure unit via dial-capture or pin interface as required.
- Alarms sent and received at ARC over all available interfaces.
- No Bad Panel Feed alarm events outstanding.

Appendix B Redcare Secure unit Generated Events

Redcare Secure generates events for system alarms. The values listed in Figure 22 are the codes that are signalled by the unit in ContactID, Fast Format and SIA modes.

Alarms sent over wireline can be differentiated from those sent over wireless by the Receiver Number field in the Automation Protocol.

Description	Pin	CID (zone)	SIA (zone)	FF (zone)	Time to Active
Low DC Input Level	985	302 (999)	YT/YR	6 (2)	E – Immediate; R – Immediate
PSTN voltage fail	955	356 (999)	LT/LR	6(5)	E – 120s; R – 30s
Bad Packet Count Threshold Exceeded	959	352 (999)	ET/ER (999)	6 (3)	E – Exceed Count;
Bad Checksum	958	311 (999)	ET/ER (993)	6 (3)	E – Exceed Count;
Missing Heartbeat	982	312 (999)	ET/ER (991)	6 (3)	E – 10 days; R – Immediate
Off Hook Timeout	957	313 (999)	ET/ER (989)	6 (3)	E – 10 Min; R – Immediate
Dial Fail	983	314 (999)	ET/ER (987)	6 (3)	E – 20 Sec; R – Immediate
Runaway Panel	956	316 (999)	ET/ER (983)	6 (3)	E – 10 Min; R – Immediate
Panel Disconnected	992	317 (999)	ET/ER (981)	5 (1)	E – 2 Min; R – Immediate
GPIP1-16	1-16	323 (901-916)	UA/UR (901-916)	7 (1)	E – Immediate; R – Immediate
Software Mismatch	979	304 (999)	ET/ER (979)	6 (3)	E – Immediate
Panel Type Mismatch	989	311 (998)	ET/ER (977)	6 (3)	E – Immediate
BSIA 175 Test	988	354 (997)	TX/TE	6 (3)	E – Immediate; R – Immediate
Unit Restarted	984	305 (995)	AT/AR (995)	5 (6)	E – Immediate; R – Immediate
Level 3 Access	978	627 (999)	RB (999)	5 (3)	E – Immediate
Panel Download	993		LB/LX (999)		E – Bypass on; R – Bypass off

Figure 22 - Redcare Secure Reported Events

Appendix C Trouble Shooting

Redcare Secure does not start up

Ensure that the DC power is connected, and that no headers have been left inserted on the board

Redcare Secure doesn't connect to Redcare Enterprise Service Platform

Check that the DRN / Agency ID (Quikc start page) is set to "0"

Check that the account has been activated in the Redcare ESP server.

Check if this Redcare secure unit has already been connected under a different account.

Check that the Config / Learn Headers are not shorted.

Alarm panel does not break dial tone

Check the connection to the alarm panel

Check if the alarm panel has been set to DTMF dialling

Plug in a standard DTMF phone and dial a digit to check that it can break dial tone

No alarms sent to ARC

Ensure that the panel is configured to report using a supported format (ContactID, Ademco High Speed, SIA).

Unexpected PSTN Voltage fail (955) alarms.

Test that the unit is correctly identifying the PSTN voltage using the following test.

Enter configuration mode with a DTMF telephone. (see DTMF configuration section)

To start the PSTN voltage test enter *59*, this will play a repeating sound until # is pressed.

The LED scrolling pattern shall stop and the power LED shall be on solid.

While running, the test shall display the PSTN line status on SS1 and SS2 LED's.

With no PSTN line voltage, SS1 and SS2 shall be off.

With a PSTN line connected SS1 and SS2 shall be solid.

With a PSTN line connected and a premises phone off-hook, SS1 shall be solid and SS2 off.

To end the PSTN voltage test key #

Line voltage monitoring can be turned off where necessary with *52*0

It can be turned back on with *52*1 (default)

Note: When Line voltage monitoring is turned on the Line in use (LIU) mechanism is overridden. If line voltage monitoring is turned off then no line voltage (955) alarms will be transmitted.

Appendix D DTMF Configuration codes

Panel Format	
* 15 * 1 #	Contact ID
* 15 * 10 #	High Speed (fast format)
* 15 * 20 #	SIA
* 15 * 30 #	Pin Only mode - Default
* 15 * 2 #	ContactID with Double Knock
* 15 * 3 #	4 + 1 express (DTMF mode only)
* 15 * 5 #	4 + 2 express (DTMF mode only)
* 15 * 11	High Speed with Double Knock
* 15 * 21 #	SIA with V21 tones
GPOP1	
* 91 * 20	BSIA Form 175 Mode – Default
* 91 * 30	Standard Path Fail Mode Active Low (Failure of any communications path causes a Low on GPOP1)
* 91 * 31	Standard Path Fail Mode Active High (Failure of any communications path causes a High on GPOP1)
* 91 * 50	Standard Path Fail Mode 2 Active Low (Failure of both communications paths causes a Low on GPOP1)
* 91 * 51	Standard Path Fail Mode 2 Active High (Failure of both communications paths causes a High on GPOP1)
*98*t1*t2*t3*t4*t5*t6#	Where the following time delays apply to GPOP1 operation in mins 0-99 t1=IP fail delay, t2=IP restore delay, t3=GPRS fail delay, t4=GPRS restore delay, t5=PSTN dial fail delay, t6=PSTN dial restore delay
* 98 * xx #	(Up to S/W Version 52) Time delay before GPOP1 operates. xx=time in minutes 1-99. default=15
GPOP2	
* 92 * 10	Remotely (ARC) Controlled Active Low (0 from ARC sets output High, 1 from ARC sets output Low) – Default
* 92 * 11	Remotely (ARC) Controlled Active High (1 from ARC sets output High, 0 from ARC sets output Low)

Continued.

GPOP3	
* 93 * 10	RPS function Active Low (Alarm sent on GPI4 sets output Low, Alarm acknowledged sets output High)
* 93 * 11	RPS function (Alarm sent on GPI4 sets output High, Alarm acknowledged sets output Low) – Default
PSTN Voltage Mon	
59 (# to end test)	Line voltage test. State of line voltage is indicated on LED's SS1 & SS2
52 0	Disable PSTN voltage monitoring
52 1	Enable PSTN voltage monitoring - Default
PSTN Pre-Dial String	
50 Predial No #	Use *0 for a pause, *1 for a star, and *2 for a hash. Example *50*9*01470# will dial a 9 followed by a pause and then 1470 to ensure CLI is used
TA Number	
* 20 * TAID # Check Digit	Set the TA (Account) number. (Optional) - Example * 20 * 4191000 # 1
Panel Callback	
17 X #	Set the panel callback number (for panel remote access) to X. Default 7
16 XX #	Set the panel callback maximum time. Default 30 minutes
IP Address settings	
10 X*X*X*X#M*M*M*M #	Set a static IP address X.X.X.X and subnet mask M.M.M.M Eg. *10* 192 * 168 * 1 * 10 # 255 * 255 * 255 * 0 #
11 G*G*G*G #	Set the Gateway address G.G.G.G Eg *11* 192 * 168 * 1 * 1 #
13 1	Switch back to DHCP mode. Default
Interface Select	
60 1	Select IP + GPRS mode
60 0	Select GPRS + Dialup PSTN mode. Default

Appendix E Secure IP (Grade 4 only) specification notes

IP Protocol: TCP

Port: 443

Data Usage / Requirements:

Agile IP Grade 4 polling is every 10 seconds a poll and response results in 288 total bytes transferred (incl IP headers). A small number of alarms will also typically be generated per day and these result in 296 bytes transferred. Overall this generates approximately 2.5 M Bytes per day, per site.

Traffic Direction:

Agile IP establishes an outgoing TCP connection from your network to the Redcare Enterprise Services Platform (ESP). Once this outgoing TCP connection has been established, traffic over that connection is 2 way.

Additional Protocols:

Only TCP is required from your network.

Port Forwarding:

No ports need to be forwarded in the incoming direction. The outgoing TCP connection connects to port 443 on the Redcare ESP network, so you would need to allow outgoing access to port 443 if you block that by default.

NAT: Not required:

GPRS Requirements:

You do not need to route GPRS traffic. The GPRS connection from the Agile IP communicator through to the Redcare ESP and on to the ARC is entirely independent of your network.

DHCP and Static Addressing:

The Agile IP communicators can be configured as either DHCP clients or with specific static IP addresses on your internal network as you prefer.

Appendix F Disposal



The symbol shown here and on the product, means that the product is classed as Electrical or Electronic Equipment and should not be disposed of with other household or commercial waste at the end of its working life.

The Waste Electrical and Electronic Equipment (WEEE) Directive (2002/96/EC) has been put in place to recycle products using the best available

recovery and recycling techniques to minimise the impact on the environment,

treat any hazardous substances and avoid the increasing landfill.

Product disposal instructions for residential users:

When you have no further use for it, please dispose of the product as per your local authority's recycling processes. For more information please contact your local authority or retailer where the product was purchased.

Product disposal instructions for business users:

Business users should return the product to the freepost address below:

**BT SUPPLY CHAIN
DARLINGTON ROAD ,
NORTHALLERTON.
NORTH YORKSHIRE
DL6 2PJ.**

Appendix G Abbreviations

AC	Alternating Current
ACK	Acknowledgement
ARC	Alarm Receiving Centre
ATE	Alarm Transmission Equipment
BSIA	British Security Industry Association
Cat 5	Category 5 cabling
CID	Contact Identification
dBm	Decibel (referenced to milliwatts)
DC	Direct Current
DHCP	Dynamic Host Configuration Protocol
DTMF	Dual Tone Multi-Frequency
EN	European Norm
ESD	Electrostatic Discharge
ESP	Enterprise Service Platform
FF	Fast Format
FME	For Mobile Equipment
g	gram
GE-UK	GPRS + Ethernet (UK version)
GP	General Purpose
GPIP	General Purpose Input Pin
GPOP	General Purpose Output Pin
GPRS	General Packet Radio Service
GSM	Global System for Mobile communication
IEC	International Electrotechnical Commission
IP	Internet Protocol
LAN	Local Area Network
LED	Light Emitting Diode
M	metre
mA	milliamp
mm	millimetre
MMCX	Micro Miniature Connection
mVpp	millivolts peak-to-peak
PC	Personal Computer
PCB	Printed Circuit Board
RF	Radio Frequency
RG	Radio Grade
RPS	Return Path Signalling
SELV	Safety Extra Low Voltage
SIA	Signal Indicated Alarm
SIM	Subscriber Information Module
SS	Signal Strength
TAID	Terminal Adaptor Identification
UC	UltraConnect
URM	Uni-Radio-Metric
V	Volts

VDC Volts (Direct Current)

Appendix H REGULATORY APPROVALS



EN54-4:1997

LIABILITY

The services and products provided by Redcare, when installed and commissioned, are only intended to provide a communications path between the equipment and a supervision centre to the extent that is reasonably practicable by use of such goods and services.

DISCLAIMER

The manufacturer or his agents disclaim responsibility for any damage, financial loss or injury caused to any equipment, property or persons resulting from any use of this equipment. The manufacturer is not liable for any purely economic loss arising from any use of this equipment. All responsibility and liability in the use of Redcare products are assumed by the user.

This unit is designed to be used in customer premises. Use of this equipment in other locations may void warranty. This unit is not intended for use in marine environments or water borne vessels.

Redcare may make changes to features and specifications at any time without prior notification in the interest of ongoing product development and improvement.