



3GSTU

Subscriber Terminal Unit

Installation Guide

redcare Helpline:

0800 671 240

CE MARKING

The STU* carries the CE approval marking in accordance with the CE Marking Directive 93/68/EEC. The STU complies with the following European Directives:-

73/23/EEC (Low Voltage Directives)
by compliance with safety specifications:-

EN60950 User Safety
EN41003 Network Safety

89/336/EEC (Electro Magnetic Compatibility Directive) as amended by 92/31/EEC
by compliance with EMC specifications:-

EN55022 Emissions Class B
EN50130-4 Immunity

99/5/EEC (Radio and Telecommunications Terminal Equipment Directive)

EN 50131-1 (Security grade 4, Environmental class 1)



* STU = Subscriber Terminal Unit

CONTENTS

INTRODUCTION	4
Scope.....	4
Static Sensitive Devices	4
Decommissioning Procedure	4
3GSTU OVERVIEW	6
Specifications	8
Safety.....	9
Power Supply	9
Compatibility	9
REN	9
INSTALLATION	10
Training Courses	10
Pre-Installation Requirements.....	10
Connecting the Telephone Line and Earth	11
Mains Fail.....	13
Tamper	13
Power Connection	13
Alarm Inputs.....	14
Output Relays.....	15
Control Output	15
Return Path Signalling Output (RPS)	15
Line Fault Output	16
Telephone Line Selection (LK1)	17
INSTALLING THE NVM	17
Pin Alarm Polarity	18
PROGRAMMING THE NVM	18
Input.....	19
Switch	19
STATUS INDICATORS	24
STU Status LED Meanings.....	25
SYSTEM COMMISSIONING	25
Testing the System	26
Warranty	27
Repairs.....	27
TROUBLESHOOTING.....	28
Chirps	28
Equipment Compatibility Issues	28

INTRODUCTION

Scope

This document is provided to support professional installation of the BT redcare range of STU products:

Model	Description	Part No.
3GSTU-12V	12 V supply, 8 pin alarms	46600-12V
3GSTU-24V	24 V supply, 8 pin alarms	46600-24V
3GSTU-PLI	Plug-in	46600-PLI
11zstu	11 Zone, 11 pin alarms	46770
fire stu-24S	24 V fire stu, 3 pin alarms (Standard build)	46600-24S
fire stu-24A	24 V fire stu, 3 pin alarms (ADT)	46600-24A
fire stu-24C	24 V fire stu, 3 pin alarms (Chubb)	46600-24C
fire stu-24G	24 V fire stu, 3 pin alarms (Gardiner)	46600-24G

Static Sensitive Devices

Static electricity is present in our everyday lives. A static charge is generated by friction, and whenever two dissimilar materials are separated. The imbalance of electrons causes a potential difference of many hundreds of volts. On discharge, a large current flows for a short time.

Many electronic components can be damaged by such static charges. Component failure may not be immediate or catastrophic. Electro-Static Discharge (ESD) can cause hidden damage to components, which will affect their reliability.

It is recommended that precautions are taken against damage due to static electricity during the installation and maintenance of the STU. Suitable ESD protection measures include ensuring that you are earthed (via a wrist strap and a 1 MO resistor) whenever you handle the unit.

Decommissioning Procedure

Important:

If the STU is in service, the Alarm Receiving Centre (ARC) must be contacted to decommission it before it is power cycled. You must follow these decommissioning instructions when there is a need to change the alarm system settings:

1. Call the ARC and request they decommission the STU.
2. Wait for the ARC to confirm that the STU is decommissioned.
3. Turn off the power to the alarm system completely (i.e. switch off the mains and disconnect the battery).
4. Make the desired changes to the alarm system.
5. Re-connect the battery and switch on the mains to re-apply power to the STU.
6. Request the ARC re-commission the STU.

7. Test the system (see page 26).

3GSTU OVERVIEW

3GSTU

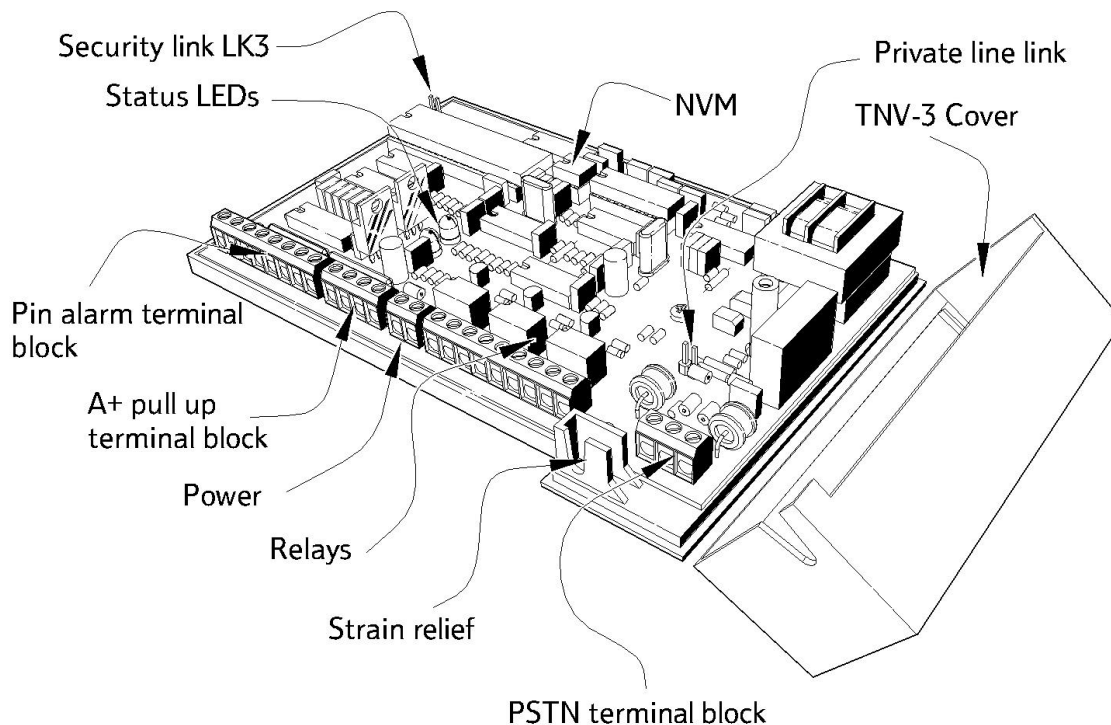

The 3GSTU is the Public Switched Telephone Network (PSTN) Subscriber Terminal Unit for the BT redcare service. It is available in a number of variants:

3GSTU-12V

The 3GSTU-12V variant is a stand-alone unit for mounting inside an alarm panel or auxiliary cabinet. This variant requires a 12 V d.c. supply. And has eight pin alarm terminals. The power supply, relay outputs and alarm inputs are connected by means of hard wiring to the terminal blocks on the 3GSTU.

3GSTU-24V

Has the same functionality as the 3GSTU-12V but operates from a 24V d.c. supply.

fire stu

Easily identified by the red plastics, the fire stu is a stand-alone unit for mounting inside an alarm panel or auxiliary cabinet. This variant has only three pin alarm terminals and a fixed Hard-ID, it requires a 24 V d.c. supply. The fire stu is intended for use in fire alarm applications that have standardised on a 24 V d.c. supply.

3GSTU-PLI

The 3GSTU-PLI variant is a plug-in unit for mounting onto certain alarm panel motherboards. With the exception of the Return Path Signalling, all power supply, output and alarm input connections are made by two connectors that protrude through the base.

The 3GSTU-PLI variant will fit the following alarm panels:

Scantronic	4700, 9100, 9600, 9800, (9500 II via adapter board).
Scantronic	808, 806, 840I
Castle Care-Tech	2300, 2500, 2700, 2900.
Modern Alarms	3000, 3200, 3400.

11zstu

The 11-Zone STU consists of a stand-alone base model 3GSTU with 8 alarm channels plus an expansion board that provides connections for alarm inputs 9, 10 and 11. This expansion board also provides connection for AC Fail input. (Note that it is NOT possible to add this board to an existing 3GSTU to expand the number of zones).

11 Zone STU

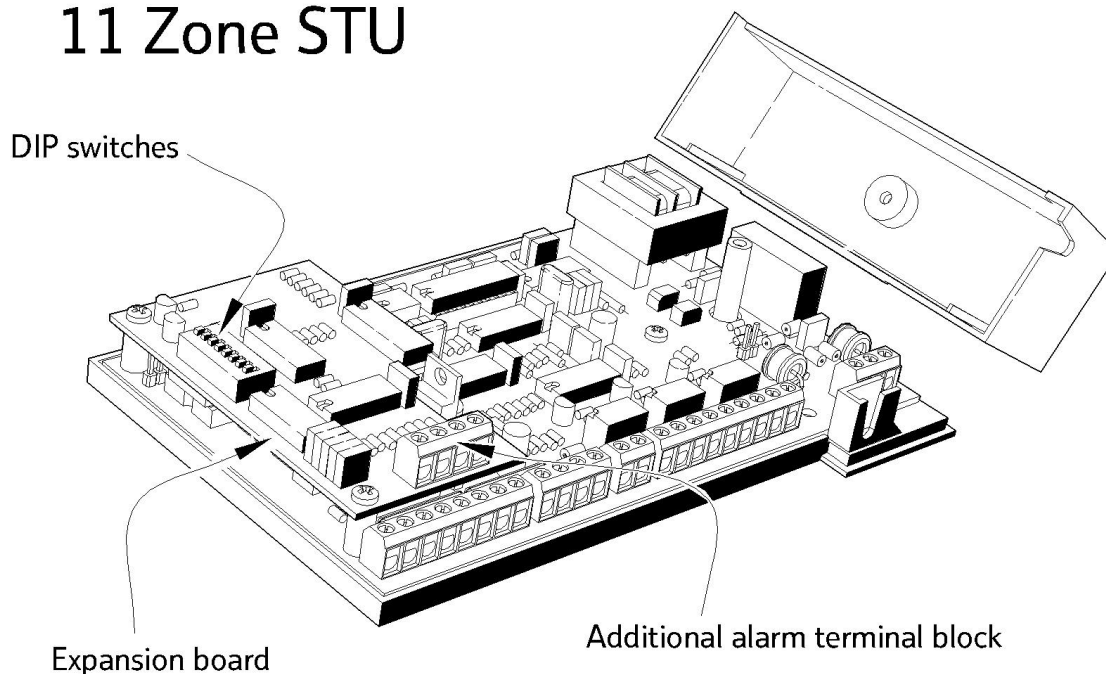

Specifications

Power supply requirements:

3GSTU-12V, 11zstu

Voltage: 10 V DC to 15 V DC

Current: 160 mA mean @12 V DC (For standby battery capacity)

Ripple/noise: 200 mV p-p max. (40 mA typical, all relays de-energised)

Low battery threshold (detected by 3GSTU-12V): $10.8 \text{ V} \pm 0.2 \text{ V}$

3GSTU-24V, fire stu

Voltage: 20 V DC to 28 V DC

Current: 160 mA max, (40 mA typ, all relays de-energised)

Ripple/noise: 200 mV p-p max

Low battery threshold (detected by 3GSTU-24x): $22.2 \text{ V} \pm 0.2 \text{ V}$

The 3GSTU-PLI variant supply requirements are:

12V Supply Voltage: 10 V DC to 15 V DC.

12V Supply Current: 80 mA typ

12V Supply Ripple/noise: 200 mV p-p max

5V Supply Voltage: 4.75 V DC to 5.25V DC

5V Supply Current: 30 mA typ

5V Supply Ripple/noise: 50 mV p-p max

Pin alarm inputs:

Logic High = +3.5 V to +30 V

Logic Low = -0.5 V to +0.8 V

Logic level outputs: (on sockets SK1 and SK2)

Logic High = 3.8 V @ 560 μA max

Logic Low = 0.4 V @ 280 μA max

These voltages are with respect to the 0V terminal on TB3

Relay contacts:

30 V, 1 A Max

Physical:

Size = 168 x 115 x 36 mm

Mass = 250 g

Environmental:

Operating ambient temperature +5° C to +40° C

Safety

The circuit board area, under the cover, is classed as a Telecommunication Network Voltage (TNV-3) circuit. All other interconnection points are classed as Safety Extra-Low Voltage (SELV) circuits. It is only necessary for this cover to be removed during installation of the PSTN wiring.

The host alarm panel or box into which the STU is installed must provide a RESTRICTED ACCESS LOCATION and a FIRE ENCLOSURE in accordance with the requirements of BS EN 60950.

It is essential that the STU is installed so that there is a gap of at least 5 mm between it and any other part of the host equipment (excluding the mounting face and plug-in connectors). If any part of the host apparatus uses or generates voltages in excess of 250 V rms or dc, obtain advice from a competent telecommunications safety engineer before you install the STU.

Power Supply

The STU must be connected to a suitable power supply. The installer must ensure that the rating of the power supply is greater than the combined rating of the STU and any other apparatus drawing power from the power supply.

The STU supply requirements are detailed on page 8.

Compatibility

The STU is designed for connection to either the Public Switched Telephone Network (PSTN) or a Private Wire (RedDIRECT). It is also compatible with earth calling lines.

It is NOT to be used with 1+1 carrier systems or a shared service.

The STU must NOT share a telephone line with other electronic data equipment, such as a facsimile machine, EPOS terminal or digital communicator unless a redcare Modem Compatibility Device (MCD) is used. (MCD cannot be used with Private wire or Earth Calling lines.)

Only one STU may be connected to any one telephone line.

REN

The Ringer Equivalence Number (REN) for the STU is 1. As a guide to the number of apparatus that can be simultaneously connected to a line, the sum of REN values for each apparatus should not exceed 4.0. A BT provided telephone is

assumed to have a REN value of 1.0 unless otherwise marked. If the STU is used with an MCD, the combined REN will be 1½.

INSTALLATION

Training Courses

BT redcare offer a free training course for installers of the redcare service. For further information call General Enquiries Tel: 0800 800 828

Pre-Installation Requirements

Before a STU installation can commence, a BT redcare Service Order must be submitted to BT redcare by the Alarm Receiving Centre. This ensures that the appropriate exchange connections have been made and a redcare block terminal 92A has been provided at the customer's premises.

To enable an NVM to be programmed the following information is required:

- a) The variant of STU is to be connected (-12V, -24V, -PLI, 11 zone or fire)
- b) The alarm channels required and the function to be assigned to each channel. The channels are typically assigned as follows:

For intruder alarm systems:

Channel 1	Fire	Channel 5	Optional
Channel 2	Personal Attack	Channel 6	Optional
Channel 3	Intruder	Channel 7	Optional
Channel 4	Opening/Closing	Channel 8	Engineer Test

For fire detection systems the fire stu has only three available channels which can be used as required.

- c) The polarity of the alarm inputs, positive applied or positive removed. (Note: for a 3GSTU-PLI (plug-in) variant all alarm inputs must be positive applied with the exception of alarm input 4 which must be positive removed).
- d) The type of line connection, PSTN (normal telephone line) or a Private Wire (RedDIRECT)
- e) The type of line monitoring function required

Important:

THE ALARM SYSTEM MUST BE TOTALLY POWERED DOWN (SWITCH OFF MAINS AND DISCONNECT THE BATTERY) BEFORE INSTALLATION CAN COMMENCE.

For certain alarm panels, the 3GSTU-PLI can be directly mounted using the "Plug-in" connections available. Locate it on the two 8-way connectors on the control panel circuit board. Take care to align the pins to the sockets on the board correctly: if they are out of alignment, damage may occur.

For other alarm panels and installations where "Plug-in" connections are not available, the unit can be wired "stand-alone". Fix the STU to the inside of the control panel using the adhesive mounting pads provided after ensuring that the control panel and STU base are free from dust or grease.

Care must be taken when connecting wires to the terminal blocks TB1,2,3,4 and TB5. The small screws can be easily damaged by over-tightening. Wiring connected to terminal blocks should be kept as short as possible to reduce the likelihood of radio frequency (RF) pickup.

Connecting the Telephone Line and Earth

The TNV circuit cover of the STU should not be removed whilst the unit is connected to the PSTN or Private Wire network.

Remove the TNV circuit cover from the STU.

Use two core telephone cable (type: 1/0.5 mm CW1308) that is not yet connected to the PSTN or Private Wire (PW) network. Strip back the insulation so that 5 mm of wire conductor is exposed. Position the cable in the plastic base as shown on page 12. Connect one core to the terminal marked A and the other to the terminal marked B.

Strip back an earth cable (green/yellow, core area greater than 1mm²) so that 5mm of wire is exposed. Position the cable in the plastic base as shown on page 12 and connect it to the terminal  marked

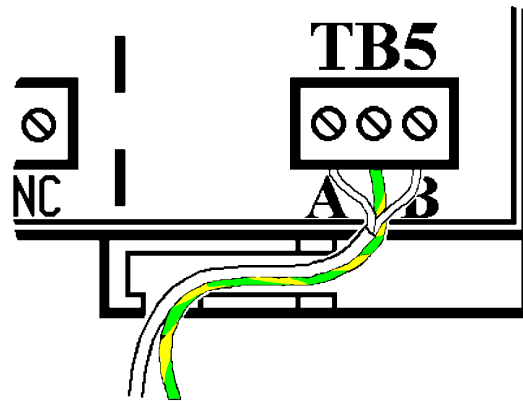

The other end of this cable must be connected to a good electrical earth.

Failure to fit an earth cable will prevent proper operation of the unit and will invalidate the warranty.

Replace the TNV circuit cover and secure in position with the screw.

Take the opposite end of the two core telephone cable and strip back both cores so that 5 mm of wire is exposed. Connect both wires to the redcare block terminal.

WARNING: the block terminal contains telecommunication network voltages.

Please note that it is important to use the correct method of connecting the STU to the BT Block Terminal 92A. The Block Terminal provides an insulation displacement connection (IDC) block for the incoming phone line. No connections, other than those made by BT, should be made to this IDC block. The STU should be connected to the screw terminals as shown.

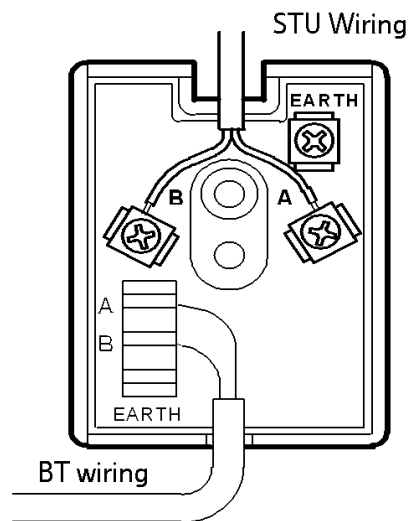

Mains Fail

If an AC fail signal is provided from the power supply, this can be connected to one of the pin alarm input terminals. For 11 Zone STU connect this to TB1-12, in this case the AC fail alarm will not be indicated on the STU status LED.

Tamper

If a tamper signal is provided this can be connected to one of the pin alarm input terminals. The tamper alarm can also be generated and sent to the ARC if the STU itself detects a tamper, such as the removal of the NVM.

Power Connection

As stated at the beginning of the Installation section, the power supply must be totally powered down (switch off mains and disconnect the battery) before making these connections.

For 3GSTU-12V units, connect a 12 V DC power supply to TB3. Connect +12V to the terminal labelled V+ and 0V to the terminal labelled 0V.

For 3GSTU-24V and fire stu units, connect a 24 V DC power supply to TB3. Connect +24V to the terminal labelled V+ and 0V to the terminal labelled 0V.

If the STU is to be powered from a separate power supply, the "0V" terminal on TB3 must be connected to the alarm panel common (0V) and the PSU 0V.

For 3GSTU-PLI units, power supply connections are made automatically when it is plugged in to the host alarm panel.

Alarm Inputs

For plug-in units, connections to the alarm panel are made by the two connectors which protrude through the base. When fitting the unit, check that SK1 pins 1 to 8 and SK2 pins 9 to 16 correspond to pins 1 to 8 and 9 to 16 on the alarm panel. The signal present on each pin is as follows:

SK1	Function	SK2	Function
Pin 1	Alarm Input 1	Pin 9	+12V
Pin 2	Alarm Input 2	Pin 10	0V
Pin 3	Alarm Input 3	Pin 11	Not Used
Pin 4	Alarm Input 4	Pin 12	+5V
Pin 5	Alarm Input 5 or 7 (see below)	Pin 13	Not Used
Pin 6	Control Output	Pin 14	Alarm Input 6
Pin 7	Not Used	Pin 15	Line Fault (output)
Pin 8	Low battery (input)	Pin 16	Alarm Input 8

Alarm 5 can be transmitted as either channel 5 or channel 7. This is achieved by fitting LK2 in either position 5 or 7. This link is not fitted on the stand alone units, as alarms 5 and 7 can be transmitted independently.

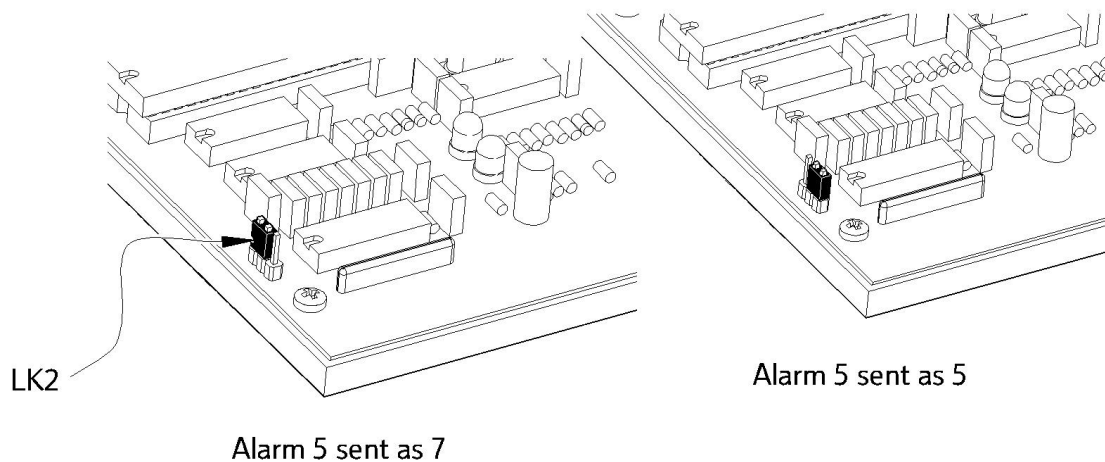

For stand alone units, alarm inputs must be connected to the alarm panel outputs. An eight way (three way for -24V) terminal block (TB1) is provided for connection of the alarm inputs.

For 11zstu, alarm inputs for channels 9, 10, 11 and AC Fail are made at the terminal block TB1 on the expansion board. Connections for alarm inputs 9, 10,

11 and AC Fail are made to terminals marked 9 through 12 of TB1 respectively. The connections are made in exactly the same way as for alarm inputs 1 to 8.

For panels which provide relay contact outputs, the common of each relay should be connected to an A+ terminal (TB2) on the STU. Either the normally open or normally closed contact should be connected to the relevant STU alarm input (TB1). For example, if the relay is energised in the alarm state, connect the relay Normally Open contact to TB1 for a positive applied alarm or connect the relay Normally Closed contact to TB1 for a positive removed alarm. Note: The A+ terminal provides four 10KΩ pull up resistors to V+. If more than four are required extra 10KΩ resistors should be connected, one end to V+ and the other to the relay common.

For panels which provide voltage outputs, each alarm signal should be connected directly to the relevant STU alarm input terminal (TB1).

Un-programmed channels can be left unconnected. If any channels have been enabled in the NVM, but are unused, these should be connected to the 'No Alarm' state. The 'No Alarm' state will be 0V for Positive Applied inputs and +12V (or V+) for positive removed inputs. This will prevent alarms being generated on the unused channels.

Output Relays

Three output relays are provided: Control, Return Path Signalling (RPS), and Line Fault. The use of any, or all, of these functions is optional. For a basic installation these outputs are not required.

Note: If an output is to be connected to a device which produces transient voltages, such as a bell, the device should be suppressed using a suitable protection diode.

Control Output

The Control Output is a general purpose output which is controlled by the Alarm Receiving Centre. It may be used for various functions including the remote resetting of alarm panels.

The 'Control Output' relay contacts (Normally Open, Common, Normally Closed) are available for connection on terminal block TB4. The relay contacts have a maximum current rating of 1 Amp.

For plug-in installations, Control Output connections are made automatically when the unit is fitted in the host alarm panel. The host alarm panel must be programmed to enable this function (TELL BACK).

Return Path Signalling Output (RPS)

The RPS output is used to indicate, at the protected premises, that the opening/closing signal has been sent to and acknowledged by the Alarm Receiving Centre.

To use the RPS function, one of the alarm inputs must be designated as an opening/closing channel (usually channel 4). The RPS output will activate when an opening or closing signal is detected. It will de-activate when the opening or closing signal has been acknowledged by the Alarm Receiving Centre. It is allowable to have more than one input designated as an opening/closing channel, but each must be acknowledged to de-activate the RPS output.

The RPS relay contacts (Normally Open, Common, Normally Closed) are available for connection on terminal block TB4. To use this option, a warning device such as a piezo bleeper or external strobe light should be connected as shown below. The maximum current rating of the relay contacts is 1 Amp.

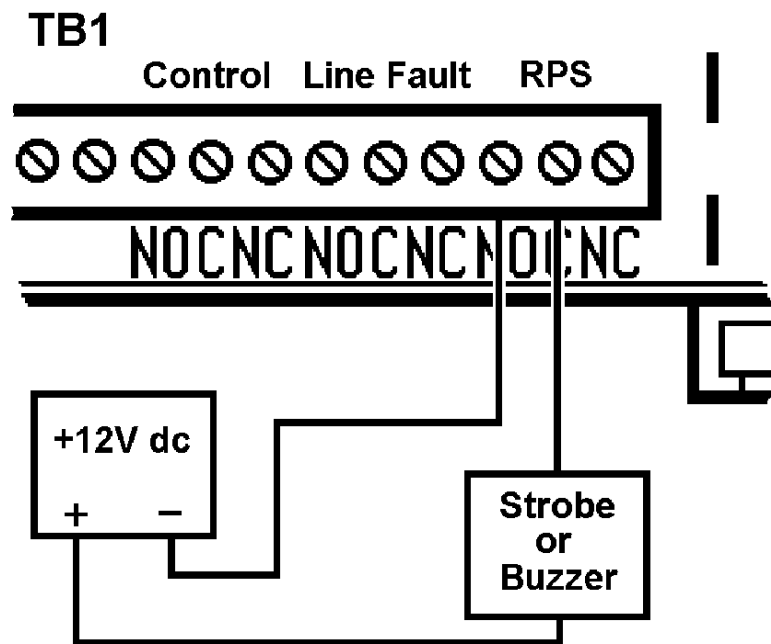

Line Fault Output

The Line Fault output is used to indicate, at the protected premises, that there is a fault with the telephone line and/or communications with the redcare system have been lost.

For stand alone units, the 'Line Fault' relay contacts (Normally Open, Common, Normally Closed) are available for connection on TB4. The maximum current rating of the relay contacts is 1.0 Amps.

For 3GSTU-PLI units, Line Fault connections are made automatically when it is fitted into the host alarm panel. The host panel must be programmed to accept this function.

The STU provides two different modes of local line monitoring, which can be selected when the NVM is programmed. The ARC must be notified if local line monitoring is to be enabled, and if so, which mode is required.

For STUs connected to normal phone lines, 'PSTN mode' should be used. This mode monitors the DC line voltage and triggers the Line Fault output within 100 seconds of a line break.

For STUs connected to private wires (RedDIRECT), 'Private Wire mode' should be used. This mode causes regular 'chirps' on the line and triggers the Line Fault output within 3 minutes of a line break.

In both PSTN and Private Wire modes, the Line Fault output will be triggered within 40 seconds if the STU has an alarm to transmit but cannot communicate with the redcare system.

Telephone Line Selection (LK1)

The STU is supplied ready to connect to the Public Switched Telephone Network (LK1 is not fitted). If the STU is to be connected to a Private Wire (RedDIRECT) a suitable link must be fitted in the position marked LK1. An NVM chip must be configured for PW use and fitted in accordance with the procedure on page 17.

If you have any doubts about the type of telephone line to which the STU is being connected, contact BT redcare for advice.

INSTALLING THE NVM

The NVM (Non-Volatile Memory) chip is a device used by the STU to store configurable parameters. This memory is retained even when the power is completely removed.

There is a socket provided (at IC2) for the fitting of a pre-programmed NVM. Suitable NVMs for use with the STU are National Semiconductor NM93C46N or Microchip Technology 93C46/P.

The NVM can be supplied pre-programmed by the ARC or the NVM can be manually programmed using a Scantronic 7200 NVM programmer (version 1.2 or 1.3 software) or a Scantronic 7300 NVM programmer (version 1.3 software).

Once fitted, the NVM can be re-programmed after careful removal using an IC extractor. If the unit has already been commissioned, see the note on page 4. The STU and alarm system must be totally powered down (switch off mains power and disconnect the battery) before fitting or removing the NVM.

Note the orientation of the device shown below and make sure it is fitted the correct way around.

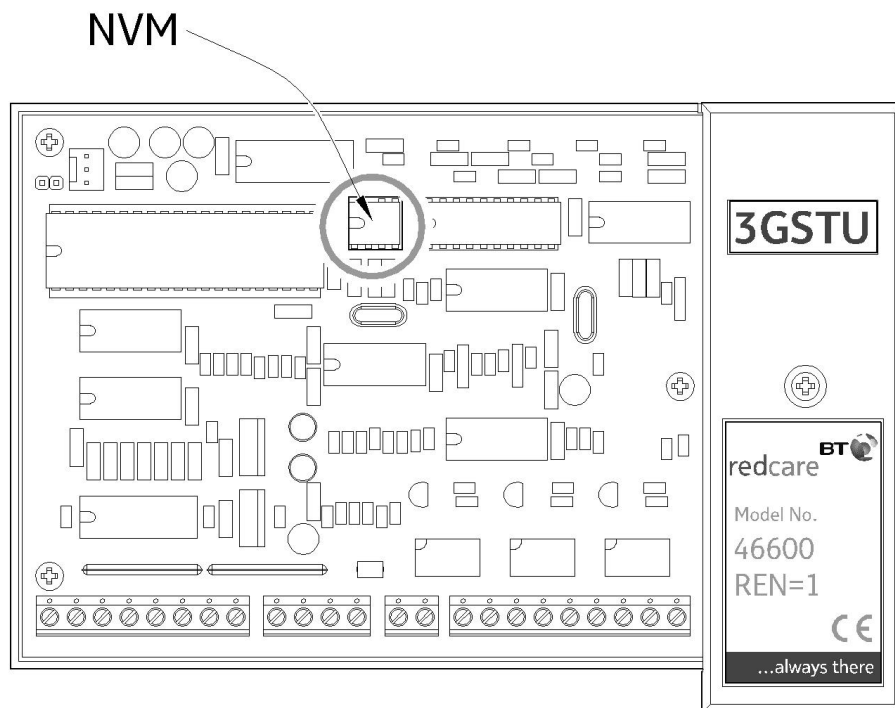

Pin Alarm Polarity

The pin alarm channels respond to the voltage level at the terminal block inputs (stand-alone mode) or the pins of SK1 and SK2 (plug-in mode). The appropriate terminal block inputs and plug-in connector socket pins are tracked together in parallel on the circuit board. Each channel can be programmed to be "Positive Applied" or "Positive Removed". This polarity is set in the NVM.

PROGRAMMING THE NVM

For 11zstu, the NVM programming does not affect the functions of alarm channels 9, 10, 11 and AC Fail. The extra alarm inputs are configured by DIP switches on the expansion board. All unused alarm inputs must be disabled. For all enabled alarm inputs, the correct polarity must be selected. Alarm inputs 9, 10, 11 and AC Fail cannot be selected as opening/closing channels.

Switches at SW1 are used to enable or disable and to select the polarity of the extra alarm inputs. The function of each switch is indicated in the table below.

Input	Switch	Off	On
9	1	Negative Applied	Positive Applied
	2	Disabled	Enabled
10	3	Negative Applied	Positive Applied
	4	Disabled	Enabled
11	5	Negative Applied	Positive Applied
	6	Disabled	Enabled
AC Fail	7	Negative Applied	Positive Applied
	8	Disabled	Enabled

Remote Programming

Once installed, the NVM can be re-programmed remotely by the ARC. Only the relay states can be adjusted unless a technician is on-site to set the STU into Secure Access Mode using LK3. Remote NVM programming is not available on the 11zstu or on older units that do not have LK3 fitted. Contact BT redcare for more information.

Manual Programming

NVMs can be programmed using a Scantronic 7200 or 7300 NVM programmer.

Apply power to the programmer (12 V DC or 12 V AC.) and set the on/off switch to position "0".

Insert the NVM in the socket marked 'COPY NVM'. Ensure that the dot on the NVM lines up with the white dot on the programmer.

Set the on/off switch to position '1' and wait for the programmer to display its version information and follow the instructions below:

V1.3
001957

Press and the screen displays:

MASTER NONE
COPY 9314/C46

Press and the screen displays:

SIMPLE 8400,8440,9056 PROGRAMMING

Press once, or twice for 7300, until the screen displays:

READ/MODIFY COPY SOCKET DATA

Press and the screen displays:

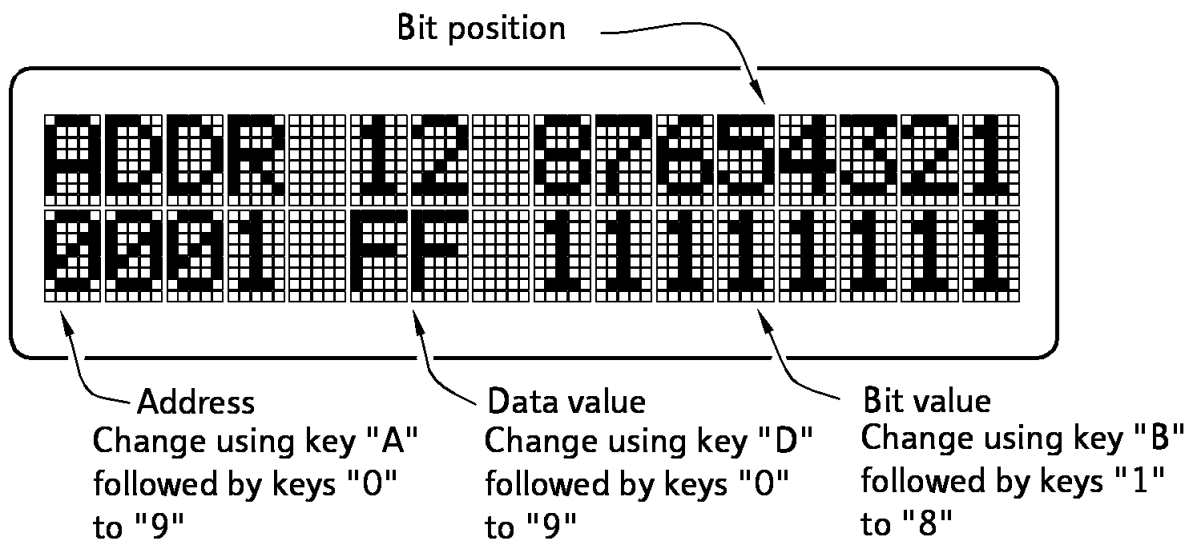

Press in sequence: The address display changes to:

0 0 3 2	
If the Control Relay is to be energised on power up press	<input type="button" value="1"/>
If the Control Relay is to be not energised on power up press	<input type="button" value="0"/>
	or
<hr/>	
If the Line Fault Relay is to be energised when the landline has failed, press	<input type="button" value="1"/>
If it is to be not energised when the landline has failed, press	<input type="button" value="0"/>
	or

Press.... to advance the address display to:

0 0 3 3	
If the Telephone Line Type is PSTN press	<input type="button" value="0"/>
If it is a private wire press	<input type="button" value="1"/>
	or
(Different key presses may be required to overcome certain equipment compatibility problems: see page 28.)	
<hr/>	
For normal Line Monitoring mode press	<input type="button" value="1"/>
For Earth Calling mode press	<input type="button" value="2"/>
	or

Press..... **YES** to advance the address display to:

0 0 3 4

For all variants Press

0

Press in sequence: **A** **4** **7** **D** The address display changes to:

0 0 4 7

Key in the first two digits of the hard ID, press yes and key in the final two digits.
(This address is ignored in 3GSTU-24x as the hard ID is fixed in ROM)
For example, a hard ID of 0567 would be entered:

0 **5** **YES** **6** **7**

Press in sequence: **A** **6** **0** **B** The address display changes to:

0 0 6 0

Use keys **1** to **8** to set the polarity of alarm pins 1 to 8.

Pressing the numbered key changes the setting of the polarity from 0 to 1, or 1 to 0. A state of 1 means positive applied and a state of 0 means positive removed.

Press in sequence: The address display changes to:

0 0 6 6

Use keys to to select the pins that are opening/closing channels. A state of 1 means that the alarm pin is an opening/closing channel a state of 0 means that it is not an opening/closing channel.

Press in sequence: The address display changes to:

0 0 7 0

Use keys to to designate alarm pins that are enabled. A state of 1 means the pin is enabled and a state of 0 means the pin is disabled. For fire stu channels 4 to 8 must be disabled.

The NVM is now completely programmed. Set the power switch to 0, remove the programmed NVM and insert it in the STU at position IC2 (see page 18).

STATUS INDICATORS

Status Indicators

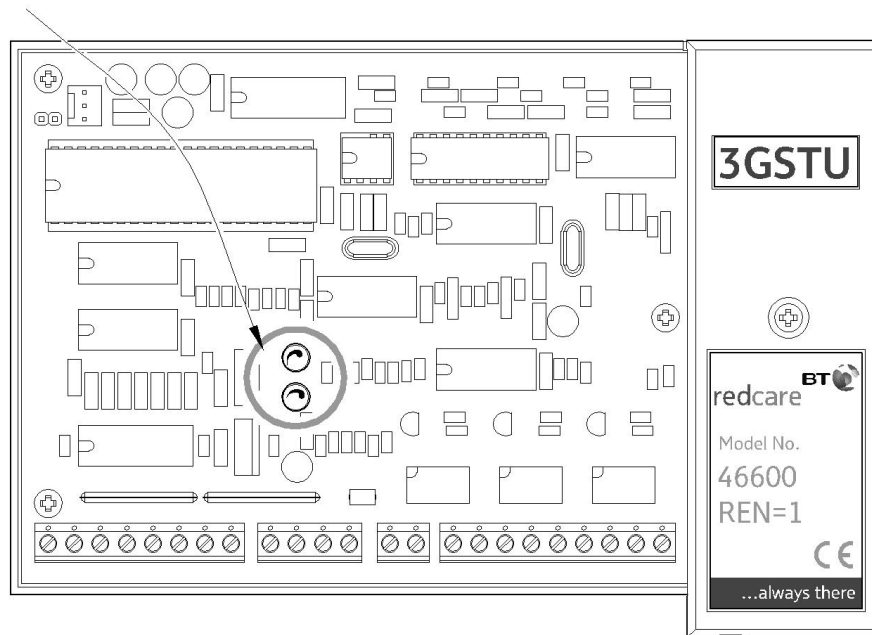

LED	Indication	Normal state
1 (green)	STU Status 1	Intermittent flash
2 (red)	STU Status 2	Off

Key to LED flash rates:

Slow

About 2¹/₂ s on, 2¹/₂ s off.

Fast

About 1¹/₃ s on, 1¹/₃ s off.

Flutter

About 12 flashes per second.

Intermittent

One or more flashes about 1¹/₃ s on and then off for more than 2¹/₂ s.

STU Status LED Meanings

The status of the 3GSTU is indicated on the LEDs in priority order - highest first. Where a high priority condition exists, it is indicated on the LED and suppresses the indication of lower priority conditions.

For example, if a battery low condition is present, battery low is indicated on the red LED regardless of the state of AC Fail.

Green flutter flash for $\frac{2}{3}$ s:

Transmitting or receiving alarm data over landline (chirp).

Green fast flash:

Battery power is low. Battery low is indicated on the LED as soon as it is detected. The battery low alarm is only transmitted after a delay.

Green slow flash:

The STU has been commissioned by the ARC.

Green permanently off:

STU is not powered.

Red permanently off:

Normal

Red fast flash:

The STU has detected an NVM configuration error.

Red flutter flash:

STU has one or more alarms or openings/closings present.

The LED flashes once for each unacknowledged alarm on pins 1 to 8 (1 to 11 for 11zstu) and is then off for a few seconds.

SYSTEM COMMISSIONING

Note 1: The STU should not be commissioned if a data device is busy using the telephone line.

Note 2: If an MCD is fitted it will disconnect the telephone or data device connected through it during commissioning.

Apply power to the alarm panel and the STU and observe the status indicators. The red and green LEDs will slow flash together (on for 2.5 seconds approx. and off for 2.5 seconds approx.).

During the commissioning procedure, the STU will be "upped" on the landline. Call the ARC, preferably using the same line as the STU, and ask them to commission the system ("Up the STU").

You will hear a short series of 'chirps' on the line. The green STU Status LED will give a short flutter each time a landline message, heard as a "chirp", is sent or received.

When the ARC confirms that the system is commissioned the green STU Status LED should flash every 5 seconds. The red STU Status LED may either be off, or produce short flashes every 10 seconds. The short flashes indicate the number of alarms triggered.

If, during the commissioning procedure, power to the STU is interrupted, even momentarily, the above procedure will have to be repeated.

Testing the System

Once the STU has been commissioned, all of the used alarm inputs and relay outputs should be tested. To test the alarm inputs you must be in contact with the ARC.

Each alarm should be tested in the following manner:

- a) Trigger the alarm (the red STU Status LED should give one quick flash every 10 seconds signifying one alarm has been triggered).
- b) Ask the ARC to confirm that it has received the alarm message.
- c) Ask the ARC to acknowledge the alarm.
- d) Remove the alarm trigger (the red STU Status LED should stop flashing).
- e) Ask the ARC to confirm that it has received the reset message.
- f) Ask the ARC to acknowledge the reset.

If personal attack buttons form part of the system they must be tested as above.

If used, the Control Output should be tested as follows:

- a) Ask the ARC to turn on the Control Output.
- b) Confirm that Control Output is activated (e.g. Remote Reset).
- c) Ask the ARC to turn off the Control Output.
- d) Confirm that the Control Output is deactivated.

If used, the RPS output should be tested as follows:

- a) Trigger the alarm that has been designated as the opening/closing channel.
- b) Confirm that the RPS warning device is activated and ask the ARC to confirm that it has received the opening message.
- c) Ask the ARC to acknowledge the opening.
- d) Confirm that the RPS warning device is de-activated.

If enabled, the Line Fault output should be tested as follows:

- a) Disconnect the STU from the telephone line (both A and B connections).
- b) If the STU is connected to the PSTN, the Line Fault output will activate within 100 s.
- c) If the STU is connected to a Private Wire (redirect) or a PSTN earth calling line, the Line Fault output will activate within three minutes.
- d) Reconnect the telephone line and verify that the Line Fault relay is de-activated.

When all of the above tests have been successfully completed, all the alarm triggers should be removed and the ARC asked to acknowledge all of the unacknowledged alarms. The STU red LED should be off and the green LED should produce a short flash every 5 seconds. This signifies that the STU is commissioned and there are no outstanding alarms.

Warranty

The warranty covers defects in materials and workmanship. The warranty is invalidated by misuse or neglect by the customer and defects caused by improper installation or operating practices. Damage such as that caused by lightning or inadequate return packaging will also void the warranty. In no event shall BT redcare be liable for any consequential damage.

Repairs

All STUs sent for repair must be returned via the distributor from which they were purchased and NOT direct to BT redcare. The NVM must be removed from the STU before it is returned for repair.

All non warranty repairs are charged at a standard fixed price plus a shipping charge and VAT.

TROUBLESHOOTING

This section describes typical problems that may arise, the symptoms, possible causes and solutions. If you have problems that you cannot resolve after consulting this section, please contact BT redcare Technical Helpline Freephone: 0800 671 240.

Chirps

The redcare system utilises an existing telephone line to provide a secure communications link between the alarm system at the protected premises and the ARC.

To facilitate this, two modes of communication are employed: a continuous inaudible low-tone, normally present all the time, and an audible 'chirp', used to transmit alarm messages and check for the presence of the STU.

These 'chirps' will not normally be heard, but they can occasionally occur as the telephone handset is lifted. This 'chirp' should be heard only once. If 'chirps' are heard regularly during conversation, please contact BT redcare for advice.

Equipment Compatibility Issues

Certain compatibility issues with specific equipment can be overcome by changing the low-tone signalling level output from the STU. Only where advised by BT redcare, the low-tone attenuation setting can be changed by re-programming the NVM. The NVM address concerned is number 33 which also contains the line monitoring mode setting. The options available are shown on page 29.

Line Type	Earth Calling Line	On Hook Atten.	Off Hook Atten.	Data Value at Address 33	Bit Value
PSTN	No	0 dB	0 dB	21	00100001
PSTN	No	0 dB	-3 dB	01	00000001
PSTN	No	0 dB	-6 dB	31	00110001
PSTN	No	0 dB	-9 dB	41	01000001
PSTN	No	-3 dB	-3 dB	51	01010001
PSTN	No	-3 dB	-6 dB	61	01100001
PSTN	No	-3 dB	-9 dB	71	01110001
PSTN	No	-6 dB	-6 dB	81	10000001
PSTN	No	-6 dB	-9 dB	91	10010001
PSTN	No	-9 dB	-9 dB	A1	10100001
PSTN	Yes	0 dB	0 dB	22	00100010
PSTN	Yes	0 dB	-3 dB	02	00000010
PSTN	Yes	0 dB	-6 dB	32	00110010
PSTN	Yes	0 dB	-9 dB	42	01000010
PSTN	Yes	-3 dB	-3 dB	52	01010010
PSTN	Yes	-3 dB	-6 dB	62	01100010
PSTN	Yes	-3 dB	-9 dB	72	01110010
PSTN	Yes	-6 dB	-6 dB	82	10000010
PSTN	Yes	-6 dB	-9 dB	92	10010010
PSTN	Yes	-9 dB	-9 dB	A2	10100010
PW	n/a	0 dB	0 dB	11	00010001
PW	n/a	0 dB	0 dB	12	00010010
PW	n/a	-3 dB	-3 dB	D1	11010001
PW	n/a	-3 dB	-3 dB	D2	11010010
PW	n/a	-6 dB	-6 dB	E1	11100001
PW	n/a	-6 dB	-6 dB	E2	11100010
PW	n/a	-9 dB	-9 dB	F1	11110001
PW	n/a	-9 dB	-9 dB	F2	11110010

Symptom	Possible Causes	Possible Solution
Problems indicated on the STU Status LEDs		
Red STU Status LED Fast flash.	a) NVM not fitted. b) NVM unprogrammed. c) NVM wrong way around. d) NVM leg bent under. e) The NVM has been removed from the STU.	a), b), c) Insert correctly programmed NVM. d) Refit NVM. e) Power down, insert the NVM and re-apply power to the STU. Ask the ARC to commission the STU again.
When an alarm is triggered the number of outstanding alarms does NOT increase. The red STU Status LED is off or the number of flashes of the red LED stays the same. The green STU Status LED intermittent flash.	a) An alarm previously transmitted on the same channel has not been acknowledged by the ARC. b) The NVM has been incorrectly programmed and the alarm channel has been disabled by mistake.	a) Ask the ARC to acknowledge any outstanding alarms. b) Re-program the NVM.
The red STU Status LED flashes up to eight times after every other flash of the green STU Status LED.	Each red LED flash represents an outstanding alarm. a) Alarm input/s may be incorrectly wired. b) Alarm information may be programmed incorrectly in the NVM.	a) Check/correct the alarm input wiring. b) i) Re-configure alarm settings. ii) Re-program the NVM.
Green STU Status LED fast flash.	Power supply and/or battery voltage is too low.	Check the operation of the power supply. Check that the back up battery is charged.

Symptom	Possible Causes	Possible Solution
ARC cannot commission the STU, and the phone line is otherwise OK. Green and red Status LEDs slow flash.	a) STU is not enabled by BT Redcare. b) Wrong phone line being used. c) Wrong STU commissioned by the ARC.	a), b), c) Seek assistance from the ARC.
ARC is reporting NO RESPONSE and chirps can be heard on the phone line. Green and red STU Status LED slow flash.	There has been a momentary power failure in the control panel.	Ask the ARC to commission the STU again.
ARC is reporting NO RESPONSE and chirps CANNOT be heard on the phone line. (Green STU Status LED slow flash.)	There is a failure of the phone line.	Report the failure to your local BT fault repair service. Phone 151 for residential customers. Phone 154 for business and RedDIRECT customers.
Problems NOT indicated by the LEDs		
The alarm panel is in a permanent local line fault condition.	The line fault output has been programmed to the wrong polarity.	Re-program the NVM.
Regular 'chirps' are heard (every 2 minutes) whenever the telephone is in use	PABX or telephone compatibility problems	Report make and model details to BT redcare Helpdesk and ask for advice.
The ARC is reporting the receipt of a channel 12 alarm but tamper pin is not active.	a) This is an internal alarm generated by the STU to indicate a tamper condition. b) The NVM has been removed from a commissioned STU.	Re-configure the NVM.

Symptom	Possible Causes	Possible Solution
The ARC is reporting the receipt of a channel 14 alarm.	This is an internal alarm generated by the STU to indicate a battery low condition.	Possible mains failure or faulty battery.
No activity on the STU, no LEDs on.	The power is off.	Check for 12V dc at TB3 V+ with respect to TB3 0V
Regular 'chirps' are heard (every 2½ to 3 minutes) whenever the telephone is in use.	The NVM has been programmed for Private Wire mode and the STU is connected to a normal phone line (PSTN).	Re-program the NVM for 'PSTN mode'.
Calls cannot be made from the STU phone line.	<ul style="list-style-type: none"> a) LK1 fitted when STU is connected to the PSTN. b) Incorrect phone line wiring to the STU. c) Faulty wiring at the redcare block terminal. d) Faulty phone line. 	<ul style="list-style-type: none"> a) Remove LK1. b) Check and correct the wiring. c) Seek assistance from the ARC. d) Report the fault to your local BT fault repair service.
The ARC is reporting the receipt of a channel 15 alarm.	This is an internal alarm generated by the STU to indicate a self test failure.	The STU has detected a fault in its internal circuitry. Replace the STU.



British Security Industry Association



Offices worldwide

The telecommunications services described in this publication are subject to availability and may be modified from time to time. Services and equipment are provided subject to British Telecommunications plc's respective standard conditions of contract. Nothing in this publication forms any part of any contract.

© 2004 British Telecommunications plc.

Registered office: 81 Newgate Street, London EC1A 7AJ

Registered in England No: 18000000

Produced in England

Please quote ref: 46606 Iss P when reordering copies of this document.

Please print on paper which meets international environmental standards.