



GSM STU EV
(Enhanced Version)

Model 47500

Subscriber Terminal Unit with GSM Backup
Facility

Installation Guide

redcare Helpline:

0800 671 240

CE MARKING

The GSM* STU* carries the CE approval marking in accordance with the CE Marking Directive 93/68/EEC. The **GSM STU EV** complies with the following European Directives:-

73/23/EEC (Low Voltage Directives)
by compliance with safety specifications:-

EN60950 User Safety
EN41003 Network Safety

89/336/EEC (Electro Magnetic Compatibility Directive) as amended by 92/31/EEC
by compliance with EMC specifications:-

EN55022 Emissions Class B
EN50130-4 Immunity

99/5/EEC (Radio and Telecommunications Terminal Equipment Directive)

2002/96/EC (Waste Electrical and Electronic Equipment Directive)



Suitable for use in systems that comply with EN 50131-1 at:
Security Grade 4, Environmental Class 1.



* GSM = Global System for Mobile communications
* STU = Subscriber Terminal Unit

CONTENTS

INTRODUCTION	4
Static Sensitive Devices.....	4
Decommissioning Procedure.....	4
GSM STU EV OVERVIEW	5
Specifications.....	6
GSM STU compatibility	7
3GSTU Replacement	7
redcare gsm Connection	7
Safety Statement.....	7
Siting	8
Power Supply	8
Line Compatibility.....	9
REN	9
INSTALLATION	9
Training Courses.....	9
Pre-Installation Requirements	9
CPE Number	9
Connecting the Telephone Line and Earth	11
Antenna.....	12
Mains Fail.....	14
Tamper.....	14
Power Connection.....	14
Alarm Inputs	14
Plug-in Compatibility Link (LK3)	16
Output Relays	16
Control Output.....	17
Return Path Signalling Output (RPS).....	17
Line Fault Relay	18
ATS Test	18
Telephone Line Selection (LK1)	18
NVM	19
Remote Programming	21
Pin Alarm Polarity	21
Learning Procedure	21
PROGRAMMING THE NVM	23
STATUS INDICATORS	30
STU Status LED Meanings	31
SYSTEM COMMISSIONING	34
Testing the System	34
Warranty.....	36
Repairs	36
TROUBLESHOOTING	36
Chirps.....	36
Substitution	37
Equipment Compatibility Issues.....	37
DISPOSAL	43

INTRODUCTION

Static Sensitive Devices

Static electricity is present in our everyday lives. A static charge is generated by friction and the separation of two dissimilar materials. An imbalance of electrons causes a potential difference of many hundreds of volts. On discharge, a large current flows for a short time.

Many electronic components can be damaged by such static charges. Component failure may not be immediate or catastrophic. Electro-Static Discharge (ESD) can cause hidden damage to components, which will affect their reliability.

It is recommended that precautions are taken against damage due to static electricity during the installation and maintenance of the **GSM STU EV**. Suitable ESD protection measures include ensuring that you are earthed (via a wrist strap and a 1 M Ω resistor) whenever you handle the unit.

Decommissioning Procedure

Important:

If the **GSM STU EV** is in service, the Alarm Receiving Centre (ARC) must be contacted to decommission it **before** it is power cycled. You must follow these decommissioning instructions when there is a need to change the alarm system settings:

1. Call the ARC and request they decommission the **GSM STU EV**.
2. Wait for the ARC to confirm that the **GSM STU EV** is decommissioned.
3. Turn off the power to the alarm system completely (i.e. switch off the mains and disconnect the battery).
4. Make the desired changes to the alarm system.
5. Re-connect the battery and switch on the mains to re-apply power to the **GSM STU EV**.
6. Request the ARC re-commission the **GSM STU EV**.
7. Test the system (see page 34).

GSM STU EV OVERVIEW

The **GSM STU EV** is a combined Public Switched Telephone Network (PSTN) Subscriber Terminal Unit and wireless alarm reporting device for the **redcare gsm** service.

The **GSM STU EV** system is designed to provide a backup communications path for the single landline connection to a premises. This allows alarms to continue to be transmitted even in the event of a landline communications failure. The Alarm Receiving Centre (ARC) will be able to continue to monitor a premises following a landline cut. It also allows line faults (as distinct from malicious line cuts) to be more positively identified. A malicious line cut will usually be accompanied by an intruder alarm transmitted over the GSM path.

In addition, the GSM signal strength is constantly monitored. Should this fall below a certain level, an alarm message will be transmitted via the landline indicating that there is a GSM fault.

During normal operation, the GSM path does not pass any data and all signalling is via the BT landline.

The GSM link becomes active:

- During the **GSM STU EV** commissioning sequence.
- If the **GSM STU EV** detects a landline communications failure.
- When the landline has failed and a pin alarm occurs.
- When a routine GSM connection test is being performed.
- If a message transmitted across the landline is not acknowledged.

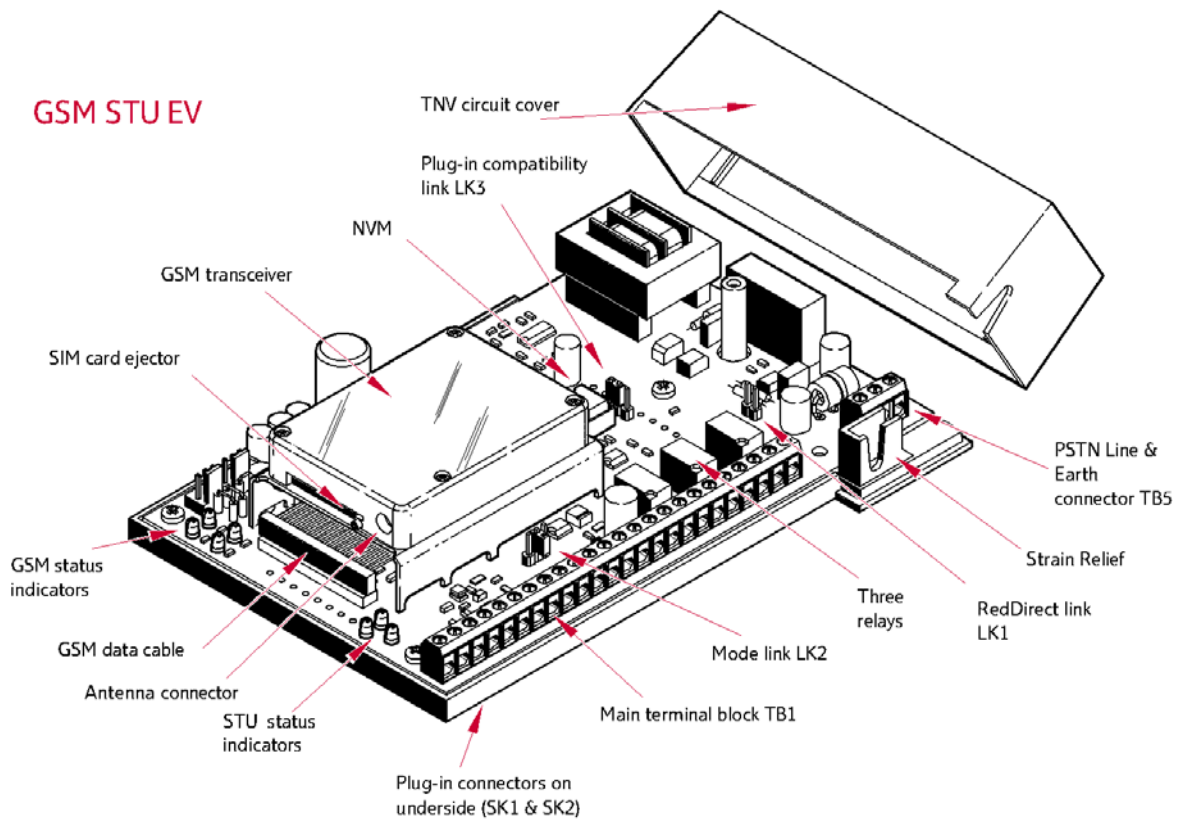

Specifications

Power supply requirements:

Voltage: 10 V DC to 15 V DC

Current: 350 mA peak @12 V DC (Required rating of power supply)
160 mA mean @12 V DC (For standby battery capacity)

Ripple/noise: 200 mV p-p max.

Low battery threshold (detected by **GSM STU EV**): $10.8 \text{ V} \pm 0.2 \text{ V}$

Pin alarm inputs:

Logic High = +3.5 V to +30 V

Logic Low = -0.5 V to +0.8 V

Logic level outputs: (on sockets SK1 and SK2)

Logic High = 3.8 V @ 560 μA max

Logic Low = 0.4 V @ 280 μA max

These voltages are with respect to the 0V terminal on TB1

Relay contacts:

30 V, 1 A Max

Physical:

Size = 168 x 115 x 36 mm

Mass = 360 g

Environmental:

Operating ambient temperature +5° C to +40° C

GSM STU compatibility

For instances where the GSM STU EV is required to behave in an identical fashion to a GSM STU, the NVM should be removed and the link LK3 be fitted to position P16. This mode of operation disables the ATS test functionality and permits pin inputs 10 and 11 to be used if required.

3GSTU Replacement

The **GSM STU EV** has been designed as a replacement for existing **3GSTU** installations where there is a need to upgrade the line to incorporate GSM backup. For a **3GSTU-12V** any existing alarm pin wiring or power connections can be re-used. These terminals are in the same relative positions as they are on the **3GSTU**. Any existing power supply needs to be adequate, see page 6. Care must be taken when replacing a **3GSTU-PLI** because of the slight differences in the plug-in connector pin-out (see page 14).

redcare gsm Connection

redcare gsm requires that the designated ARC be connected to the **redcare** Digital Services Platform (DSP).

Safety Statement

The circuit board area, under the cover, is classed as a Telecommunication Network Voltage (TNV-3) circuit. All other interconnection points are classed as Safety Extra-Low Voltage (SELV) circuits. It is only necessary for this cover to be removed during installation of the PSTN wiring. A protective earth connection is required to the terminal block TB5.

GSM STU EV is designed for host-independent fitment.

The host alarm panel or box into which the **GSM STU EV** is installed must provide a RESTRICTED ACCESS LOCATION and a FIRE ENCLOSURE in accordance with the requirements of BS EN 60950.

It is essential that the **GSM STU EV** is installed so that there is a gap of at least 5 mm between it and any other part of the host equipment (excluding the mounting face). If any part of the host apparatus uses or generates voltages in excess of

250 V rms or dc, obtain advice from a competent telecommunications safety engineer before you install the **GSM STU EV**.

Siting

When surveying the site please remember that the **GSM STU EV** operates in a similar way to an ordinary mobile telephone, therefore any restrictions on the use of mobile telephones in the area will also apply to the **GSM STU EV**.

Premises such as hospitals, petrol stations, airports, blasting areas etc. may operate a mobile telephone restriction in certain areas. Always ensure that the chosen site is free of any mobile telephone restrictions and advise the end user so that they are aware, should any restrictions come into force in the future.



It is useful to perform a signal strength test during a pre-installation site visit. This task requires the use of an O2 connected digital GSM mobile telephone. To perform a GSM signal strength test:

1. Determine where the **GSM STU EV** enclosure will be eventually situated.
2. Place the phone where the **GSM STU EV** is to be installed, switch it on and observe the signal strength.

If the signal strength is weak, try to find a better position for the **GSM STU EV**. If required, higher gain extension antennas and extension cables are available at extra cost. For further information, contact BT redcare products, telephone number 08702 400 503.

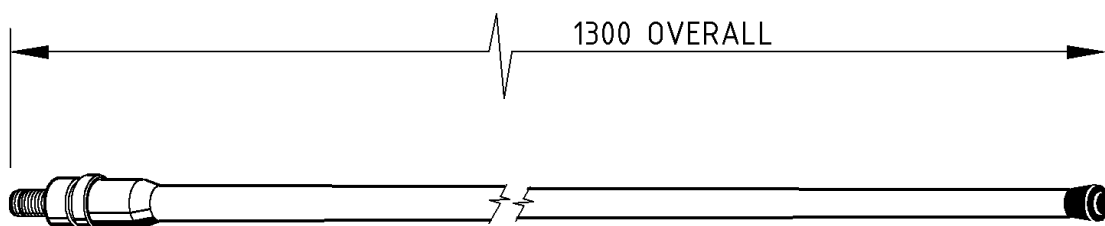

Power Supply

The **GSM STU EV** must be connected to a suitable power supply. The installer must ensure that the rating of the power supply is greater than the combined rating of the **GSM STU EV** and any other apparatus drawing power from the power supply.

The **GSM STU EV** supply requirements are detailed on page 6.

Line Compatibility

The **GSM STU EV** is designed for connection to either the Public Switched Telephone Network (PSTN) or a Private Wire (RedDIRECT). It is also compatible with earth calling lines.

It is NOT to be used with 1+1 carrier systems or a shared service.

The **GSM STU EV** must NOT share a telephone line with other electronic data equipment, such as a facsimile machine, EPOS terminal or digital communicator unless a **redcare** Modem Compatibility Device (**MCD**) is used. (**MCD** cannot be used with Private wire or Earth Calling lines.)

Only one **GSM STU EV** may be connected to any one telephone line.

REN

The Ringer Equivalence Number (REN) for the **GSM STU EV** is 1.0. As a guide to the number of apparatus that can be simultaneously connected to a line, the sum of REN values for each apparatus should not exceed 4.0. A BT provided telephone is assumed to have a REN value of 1.0 unless otherwise marked. If the **GSM STU EV** is used with an MCD, the combined REN will be 1½.

INSTALLATION

Training Courses

BT redcare offer a free training course for installers of the **redcare gsm** service. For further information call General Enquiries Tel: 0800 800 828

Pre-Installation Requirements

Before a **GSM STU EV** installation can commence, a **redcare** Service Order must be submitted to **BT redcare** by the Alarm Receiving Centre. This ensures that the appropriate exchange connections have been made and a **redcare** block terminal 92A has been provided, if required, at the customer's premises.

CPE Number

The CPE (Customer Premises Equipment) number of the **GSM STU EV** must match that on the **redcare** service order allocated to the premises. The CPE number can be found on the outer **GSM STU EV** packaging as well as on the **GSM STU EV** circuit board itself (see below).

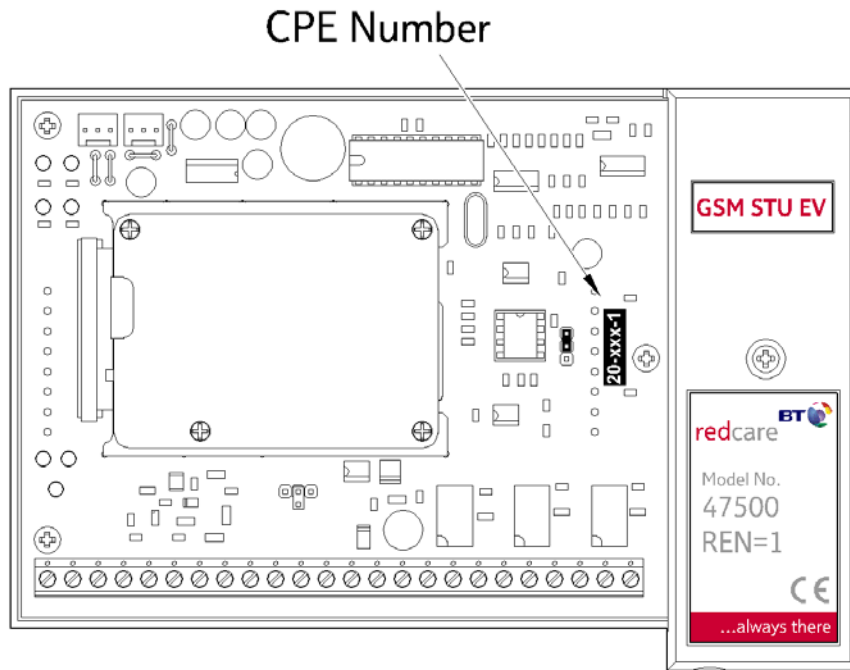

BT redcare maintain a database of the unique CPE numbers matched to the associated PSTN telephone number and the mobile phone number of the GSM unit. For this reason the SIM card in the GSM unit cannot be changed or used in any other installation.

Important:

THE ALARM SYSTEM MUST BE TOTALLY POWERED DOWN (SWITCH OFF MAINS AND DISCONNECT THE BATTERY) BEFORE INSTALLATION CAN COMMENCE.

For certain alarm panels, the **GSM STU EV** can be directly mounted using the "Plug-in" connections available. Locate it on the two 8-way connectors on the control panel circuit board. Take care to align the pins to the sockets on the board correctly: if they are out of alignment, damage may occur.

For other alarm panels and installations where "Plug-in" connections are not available, the unit can be wired "stand-alone". Ensure that the supplied mounting blocks and the **GSM STU EV** base are free from dust or grease. Bond the double-sided adhesive pads to each side of the blocks as shown, and affix them to the underside of the **GSM STU EV**. The assembly can then be fitted onto a clean, flat surface within the host enclosure.

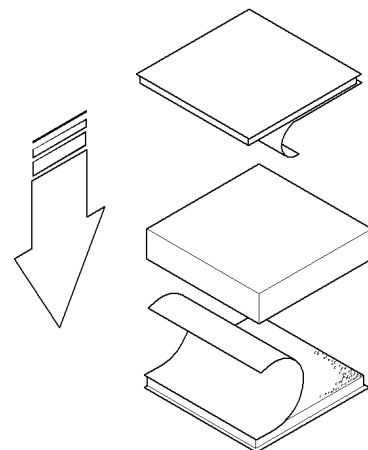

Care must be taken when connecting wires to the main terminal block TB1 and the telephone terminal block TB5. The small screws can be easily damaged by over-tightening. Wiring connected to terminal block TB1 should be kept as short as possible to reduce the likelihood of RF pickup.

Connecting the Telephone Line and Earth

The TNV circuit cover of the GSM STU EV should not be removed whilst the unit is connected to the PSTN or Private Wire network.

Remove the TNV circuit cover from the **GSM STU EV**.

Use two core telephone cable (type: 1/0.5 mm CW1308) that is not yet connected to the PSTN or Private Wire (PW) network. Strip back the insulation so that 5 mm of wire conductor is exposed. Position the cable in the plastic base as shown on page 11. Connect one core to the terminal marked A and the other to the terminal marked B.

Strip back an earth cable (green/yellow, core area greater than 1mm²) so that 5mm of wire is exposed. Position the cable in the plastic base as shown on page 11 and connect it to the terminal marked \perp

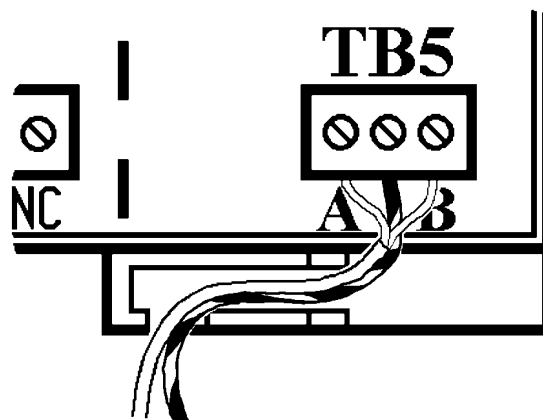

The other end of this cable must be connected to a good electrical earth.

Failure to fit an earth cable will prevent proper operation of the unit and will invalidate the warranty.

Replace the TNV circuit cover and secure in position with the screw.

12

Take the opposite end of the two core telephone cable and strip back both cores so that 5mm of wire is exposed. Connect both wires to the **redcare** block terminal.

WARNING: the block terminal contains telecommunication network voltages.

Please note that it is important to use the correct method of connecting the STU to the BT Block Terminal 92A. The Block Terminal provides an insulation displacement connection (IDC) block for the incoming phone line. No connections, other than those made by BT, should be made to this IDC block. The **GSM STU EV** should be connected to the screw terminals as shown.

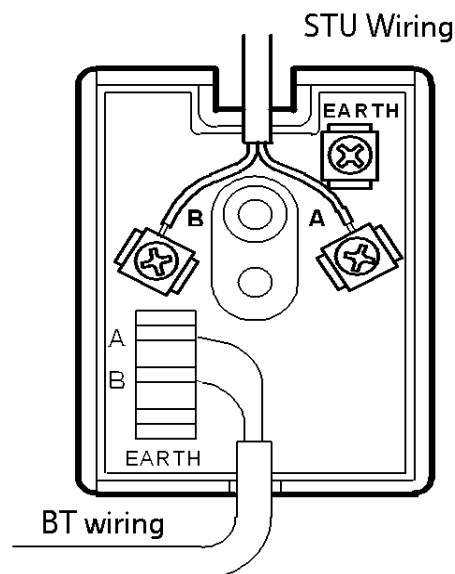

Antenna

Note: The antenna will emit Radio Frequency radiation in the same way as that of a mobile phone.

The antenna provided is a flat type (115 x 65 x 17mm) and must be mounted indoors, on a flat horizontal surface, sufficiently close that it can be connected to the **GSM STU EV**. The antenna is self-adhesive and will bond firmly to any clean, dry and flat surface. Make a suitable hole, (typically 11mm diameter) in the top of the box in which the **GSM STU EV** is fitted. Prevent swarf from entering the enclosure as it could cause internal short circuits.

Remove any burrs from the hole, pass the RF cable through it and place the antenna in position. It is advisable not to bond the antenna onto the box at this stage. Wait until the system has been tested, as it is difficult to remove once attached.

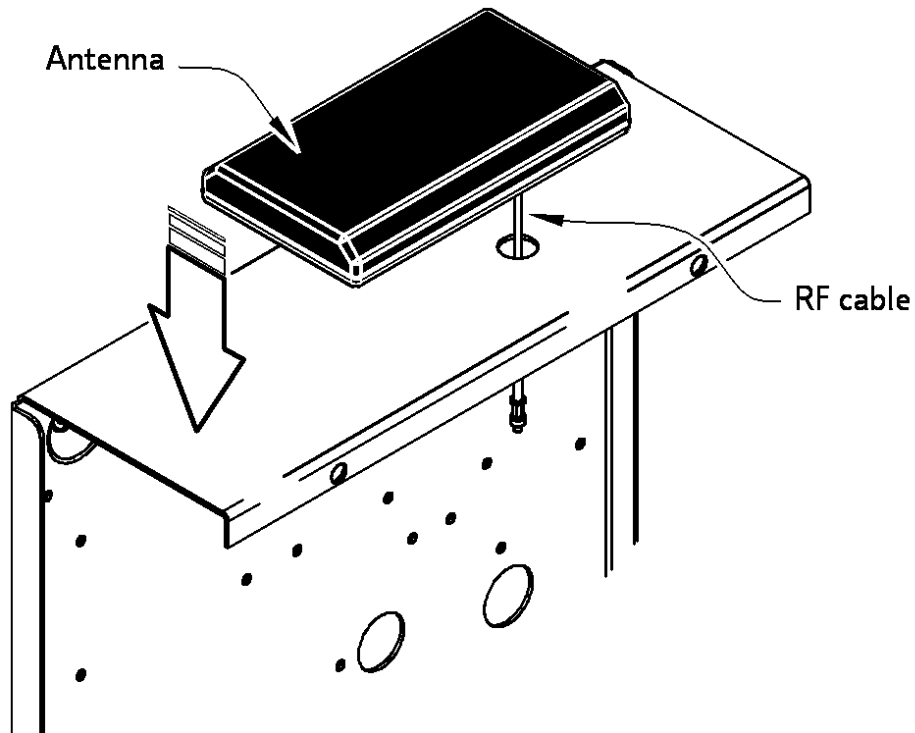

Try to route the RF cable away from any other wiring within the box to reduce the likelihood of interference. Carefully connect the RF cable to the GSM module on the **GSM STU EV**. The connector is a micro-miniature co-axial (MMCX) screened type and is easily damaged. The connector has a positive locking device and will click when correctly mated.

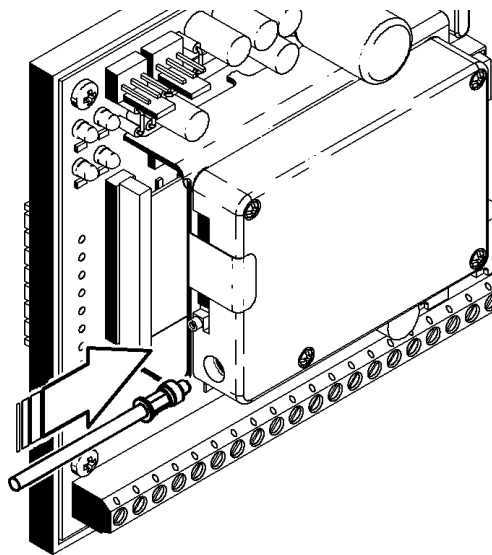

Mains Fail

If an AC fail signal is provided from the power supply, this should be connected to the terminal marked F on TB1.

Tamper

If a tamper signal is provided this should be connected to the terminal marked T on TB1. The tamper alarm can also be generated and sent to the ARC if the **GSM STU EV** itself detects a tamper, such as the removal of the NVM.

Power Connection

As stated at the beginning of the Installation section, the power supply must be totally powered down (switch off mains and disconnect the battery) before making these connections.

For both plug-in and stand-alone installations, the power must always be provided to the screw terminals at TB1. The power supply must be arranged such that the **GSM STU EV** is powered simultaneously to, or before, the alarm panel to which it is connected.

DAMAGE CAN OCCUR IF THE ALARM PANEL IS POWERED AND THE GSM STU EV IS NOT.

The supply to the **GSM STU EV** must be provided by hard wiring the TB1 screw terminals to a suitable power source. Connect +12V to the terminal labelled V+ and 0V to the terminal labelled 0V. This power wiring must be less than 3m in length and use wires having core areas of at least 1mm². The **GSM STU EV** will take a peak current of 350mA from the 12V supply, when the GSM transceiver is in operation. The current consumption otherwise is typically 160 mA.

Alarm Inputs

For “Plug-in” installation, alarm pin connections are made automatically when the **GSM STU EV** is plugged in to the host alarm panel. When fitting the **GSM STU EV**, check that the signals presented by the alarm panel match those required by the STU, for the two sockets SK1 and SK2. The pins have been designated the following functions on the **GSM STU EV**:

For plug-in installations, be sure that no wires are ever connected to the terminals 1 to 8 on TB1. Terminals 9, T & F can be connected if these channels are required in addition to those present on the plug-in connectors (SK1 & SK2).

For stand-alone installations, alarm input terminals on terminal block TB1 must be connected to the alarm panel outputs. Unused channels can be left unconnected.

The TB1 terminal marked ⑧ is reserved for GSM failure, and the ATS Test function in accordance with BSIA form 175.

SK1	Function	SK2	Function
Pin 1	Alarm Input 1	Pin 9	Not Used <i>[+12V on 3GSTU]</i>
Pin 2	Alarm Input 2	Pin 10	Signal Ground <i>[0V supply on 3GSTU]</i>
Pin 3	Alarm Input 3	Pin 11	ATS Test (via LK3)
Pin 4	Alarm Input 4	Pin 12	Not Used <i>[+5V on 3GSTU]</i>
Pin 5	Alarm Input 5 <i>[5 or 7 on 3GSTU]</i>	Pin 13	Alarm Input 6 <i>[Not used on 3GSTU]</i>
Pin 6	Tell Back (output) <i>[Control Output on 3GSTU]</i>	Pin 14	Alarm Input 7 <i>[Alarm 6 on 3GSTU]</i>
Pin 7	Comms Fail (output) <i>[Not used on 3GSTU]</i>	Pin 15	Line Fault (output)
Pin 8	Low battery (input)	Pin 16	Alarm Input 8 via LK3

Note: If ATS Test is used by the panel on the plug-in connector, it must be linked to alarm 8 using the jumper at LK3 in position P11.

Terminal Block TB1 Alarm Channel Configuration

Chan. No.	TB1 Ident	Function
1	1	Fire
2	2	Hold Up Alarm
3	3	Intruder
4	4	Opening / Closing
5	5	Zone Omit
6	6	Optional
7	7	Confirmed
8	Ⓢ	GSM fail / ATS Test (reserved)
9	9	Optional
10	10	ATS GSM Test (reserved)
11	11	ATS Landline Test (reserved)
12	T	Tamper
13	F	AC Fail

Plug-in Compatibility Link (LK3)

Some newer alarm panels use pin 11 as the ATS Test function on the plug-in connectors, whilst older panels may use pin 16 as alarm 8. **GSM STU EV** is supplied with an NVM (IC10) programmed and fitted to enable ATS Test mode (see page 18). The jumper, at LK3, is fitted as supplied, to enable compatibility with plug-in panels using the ATS test feature (SK2, pin11 connected to pin alarm 8 for ATS test).

Plug-in compatibility link settings

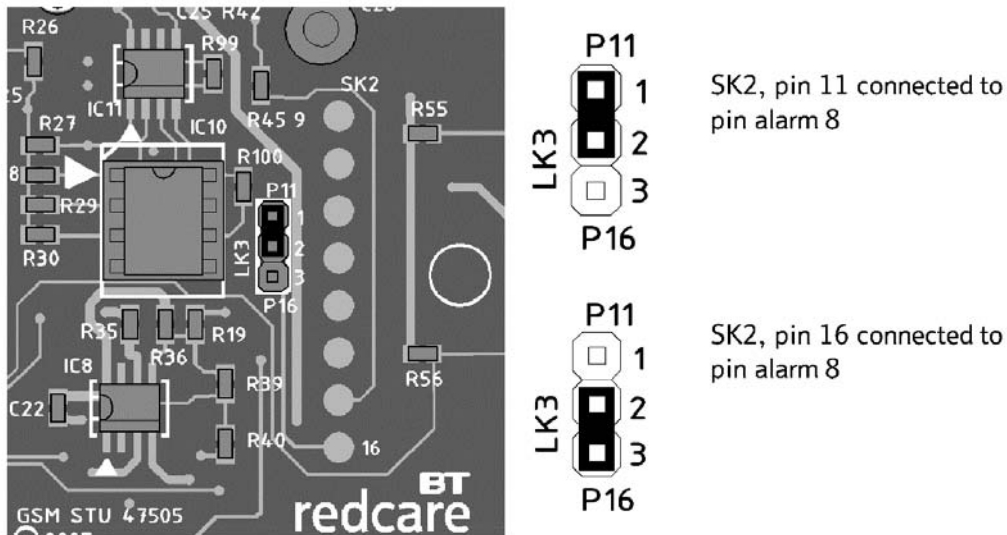

Set the jumper in the lower position for use with older plug-in panels that use SK2, pin 16 as alarm 8. For stand-alone (wired) installations the setting is irrelevant.

Output Relays

Three output relays are provided: Control, Return Path Signalling (RPS), and Line Fault.

Note: If an output is to be connected to a device which produces transient voltages, such as a bell, the device should be suppressed using a suitable protection diode. Each relay's contacts (Normally Open, Common, Normally Closed) are available for connection on terminal block TB1. The relay contacts have a maximum current rating of 1 Amp.

GSM STU EV can be programmed to indicate communications path failures in different ways. Available options include the **Line Fault Relay** indicating that both paths have failed (default); the **Line Fault Relay** indicating that one of the two paths have failed; or landline and GSM path failures may be indicated on a combination of two of the three available relays. These alternative modes of operation are not suitable for a **GSM STU EV** used as a plug-in.

Control Output

The Control Output can be used as a general purpose output which is controlled by the Alarm Receiving Centre. It may be used for various functions including the remote resetting of alarm panels. Additionally, this relay can be used in conjunction with the Line Fault relay to indicate discrete communication path fails at the protected premises (in this mode, the Control Output relay is no longer controlled by the ARC)

For plug-in installations, Control Output connections are made automatically when the unit is fitted in the host alarm panel. The host alarm panel must be programmed to enable this function (TELL BACK).

Return Path Signalling Output (RPS)

The RPS output is used to indicate, at the protected premises, that the opening/closing signal has been sent to and acknowledged by the Alarm Receiving Centre.

To use the RPS function, one of the alarm inputs must be designated as an opening/closing channel (usually channel 4). The RPS output will activate when an opening or closing signal is detected. It will de-activate when the opening or closing signal has been acknowledged by the Alarm Receiving Centre. It is allowable to have more than one input designated as an opening/closing channel, but each must be acknowledged to de-activate the RPS output.

To use this option, a warning device such as a piezo bleeper or external strobe light should be connected as shown below. The maximum current rating of the relay contacts is 1 Amp.

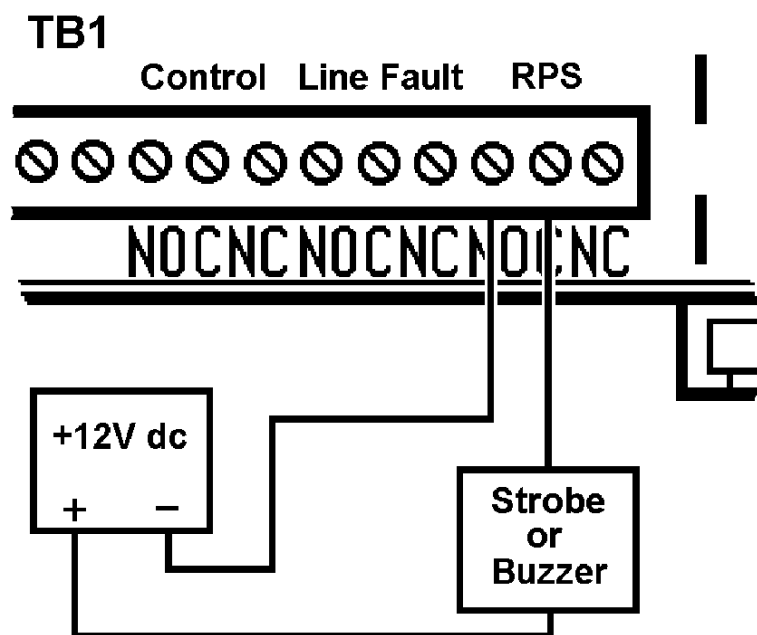

Line Fault Relay

The Line Fault Relay is used to indicate, at the protected premises, that one or both, the GSM and landline (PSTN or Private Wire) communication paths have failed. For plug-in installations, Line Fault connections are made automatically when it is fitted into the host alarm panel. The host panel must be programmed to accept this function.

ATS Test

The **GSM STU EV** is supplied with an NVM fitted, which enables the Alarm Transmission System test function. The ATS test function allows the alarm panel (and ARC) to distinguish whether one or both paths have failed in the event of a communications failure. The Line Fault signal (SK2 pin 15 or the Line Fault relay), and the ATS test signal (SK2 pin 11 or Alarm Pin 8 on TB1) are used in accordance with BSIA form 175. This is available free of charge from the BSIA or downloadable at:

http://www.bsia.co.uk/pdfs/Form_175.pdf

The alarm panel must also conform to this standard for the function to work correctly. The alarm panel can request an ATS test by applying the ATS Test signal, the **GSM STU EV** then communicates with the ARC on both the GSM wireless path and the landline. If no communication path faults are detected by the **GSM STU EV**, the ARC will receive a pin alarm 10 over the GSM path and a pin alarm 11 over the landline. When reset, these will complete the end-to-end test.

If the alarm panel asserts the ATS test pin/channel during a line fault the **GSM STU EV** will signal to the alarm panel whether it is a dual path or single path failure in accordance with BSIA form 175, using the line fault output and relay.

To deactivate the ATS test function, the plug-in NVM can be carefully removed or re-programmed to suit (see page 19). For plug-in panels, LK3 may also have to be changed (see page 16).

Telephone Line Selection (LK1)

The **GSM STU EV** is supplied ready to connect to the Public Switched Telephone Network (LK1 is not fitted). If the **GSM STU EV** is to be connected to a Private Wire (RedDIRECT) a suitable link must be fitted in the position marked LK1. An NVM chip must be configured for PW use and fitted in accordance with the procedure on page 19.

If you have any doubts about the type of telephone line to which the STU is being connected, contact **BT redcare** for advice.

NVM

The NVM (Non-Volatile Memory) chip is an optional device used by the **GSM STU EV** to store configurable parameters. This memory is retained even when the power is completely removed.

The **GSM STU EV** contains a factory default configuration stored in its permanently fitted EEPROM (Electrically Erasable Programmable Read Only Memory). The default configuration (with no NVM fitted at IC10) is:

PSTN with line monitoring.

Control Relay not energised at power up and managed by the ARC.

Line Fault Relay energised and plug-in Line Fault signal asserted on failure of both communication paths.

Line Monitoring enabled.

Pin alarms 1 to 11, tamper and AC Fail enabled.

All used alarm inputs, with the exception of alarm input 4, set to positive applied.

Alarm input 4 set to positive removed.

Channel 4 set as an opening/closing channel.

A pre-programmed NVM is fitted (at IC10), the configuration stored in this NVM is the same as that shown above except that ATS test mode is enabled (see page 18). Any settings in the NVM override those in the EEPROM configuration. If the default configuration, listed above, is required, the NVM can be removed. Any changes to the configuration, other than pin alarm polarity, must be made by re-programming and re-fitting this device.

Suitable replacement NVMs for use with the **GSM STU EV** as IC10, are Microchip 93LC46B-I/PG OR 93LC46C-I/PG.

The NVM can be programmed using a Scantronic 7200 NVM programmer (version 1.2 or 1.3 software) or a Scantronic 7300 NVM programmer (version 1.3 software).

The NVM can be re-programmed after careful removal using an IC extractor. If the unit has already been commissioned, see the note on page 4. The **GSM STU EV** and alarm system must be totally powered down (switch off mains power and disconnect the battery) before fitting or removing the NVM.

Note the orientation of the device shown below and make sure it is fitted the correct way around.

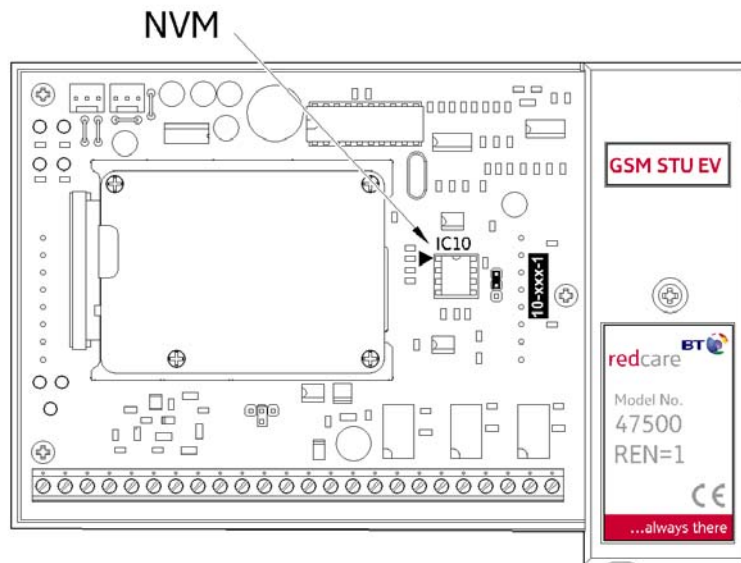

Power on the **GSM STU EV**. The yellow STU status LED will fast flash indicating that the new NVM has been detected.

Remove the Mode link (LK2) from its neutral position and place it in the security position as shown.

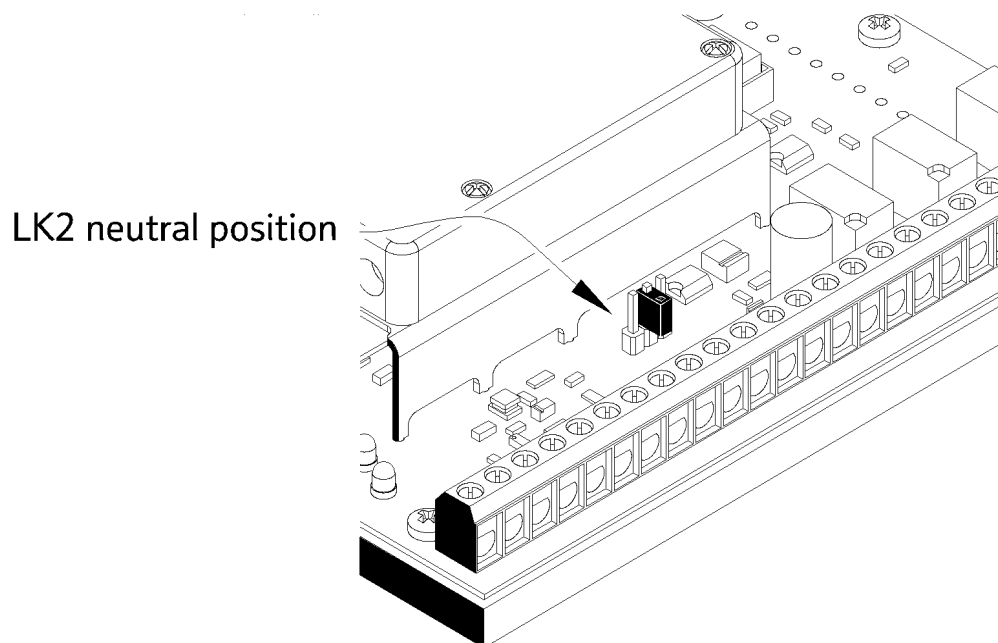

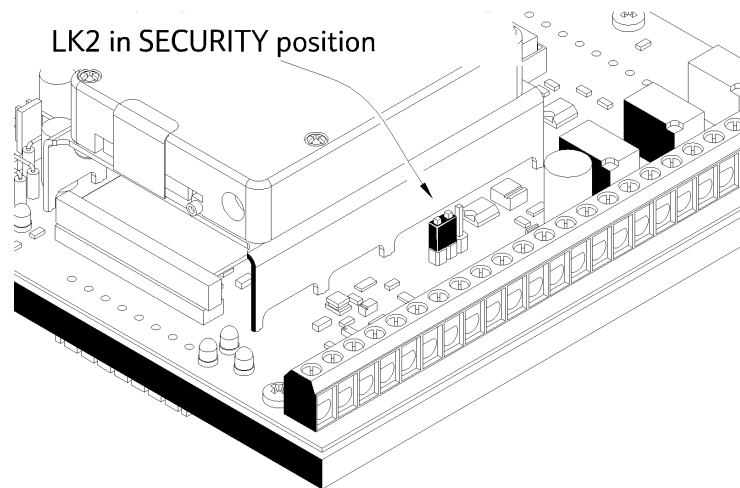

Leave LK2 in this position for three seconds. During this time the **GSM STU EV** stores the "NVM present" setting in its EEPROM so that it can re-start correctly should a complete power fail occur in the future.

Remove the security link and store it in the "Neutral" position on LK2.

Remove power from the **GSM STU EV** completely.

Remote Programming

The EEPROM or NVM, if fitted, can be re-programmed remotely by the ARC. Only the relay states can be adjusted unless a technician is on-site to set the **GSM STU EV** into Security Mode using LK2. Contact **BT redcare** for more information.

Pin Alarm Polarity

The pin alarm channels respond to the voltage level at the terminal block inputs (stand-alone mode) or the pins of SK1 and SK2 (plug-in mode). The appropriate terminal block inputs and plug-in connector socket pins are tracked together in parallel on the circuit board. Each channel can be programmed to be "Positive Applied" or "Positive Removed". This polarity is set to a default state in the EEPROM (see page 19). It can also be set in the NVM, or the **GSM STU EV** can "learn" the polarity as detailed below.

Learning Procedure

Ensure that all the used channels are connected and set to be in their **non alarm** states.

Note: All channels will be enabled by the learning procedure.

If the tamper pin "T" is to be used, the learnt polarity in "LEARN" mode may be wrong if the alarm panel door is open. Similarly, if a pin is designated an

22

"Opening/Closing" channel, the learnt polarity in "LEARN" mode will be reversed.

For stand-alone applications (**NOT PLUG-IN**), these problems can be overcome by hard wiring the terminal block pins "4" and "T" to 12 V or 0 V as required during the "LEARN" process. (Any connections to the alarm panel on these pins must first be removed.)

If the learning procedure cannot be used to program the desired polarities, a plug-in NVM must be used.

If the unit has already been commissioned, decommission and power off the alarm system as detailed on page 4.

Power on the **GSM STU EV** and place the mode link at LK2 into the Security position (see page 21). Leave the link in this position for two seconds and then remove it and place it across the adjacent pins into the "Learn" position as shown.

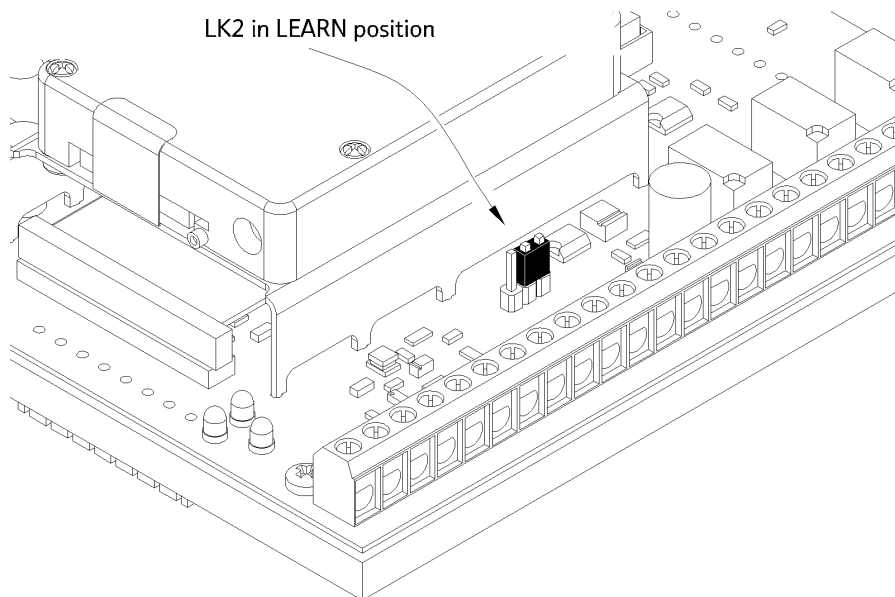

After five seconds, remove the link and return it to the "neutral" position.

The **GSM STU EV** will now learn the polarity of each alarm channel and store this data in its NVM (if fitted) and in its EEPROM, overwriting any polarity data already there. During this process, the yellow STU Status LED4 will flash very quickly for a few seconds and then the STU will reset.

If the learning procedure is required again, the whole procedure must be performed starting from "Learning Procedure" on page 21. In some cases, particularly **GSM STU EV** plug-in installations, it may be difficult to perform the Learn Procedure because not all the alarm pins can be set to their normal state for the **GSM STU EV** to learn. This problem may be resolved by using the Learn Procedure with the **GSM STU EV** disconnected from the panel as described below:

1. Completely disconnect the **GSM STU EV** from the alarm panel.
2. Connect all pins that are to be "positive removed" to the V+ output, and leave all other alarm pins unconnected.
3. Apply 12 V dc power to the **GSM STU EV**.
4. Perform the Learn Procedure.
5. Disconnect the power and remove all connections to the alarm pins.
6. Install the **GSM STU EV**.

For example, the **GSM STU EV** below is set up to learn the configuration of alarm pin 4 as "Positive Removed" and all other alarm pins "Positive Applied".

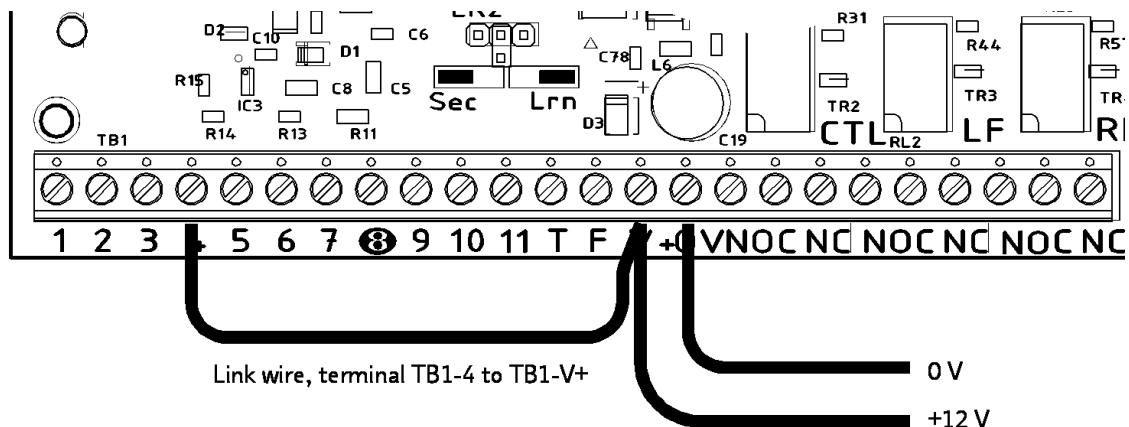

PROGRAMMING THE NVM

The following procedure should be followed when programming NVMs for the **GSM STU EV** using a Scantronic 7200 or 7300 NVM programmer.

Apply power to the programmer (12V DC or 12V AC.) and set the on/off switch to position "0".

Insert the NVM in the socket marked 'COPY NVM'. Ensure that the dot on the NVM lines up with the white dot on the programmer.

Set the on/off switch to position '1' and wait for the programmer to display its version information, for example:

V1.3
001957

YES Press and the screen displays:

MASTER NONE
COPY 9314/C46

YES Press and the screen displays:

SIMPLE 8400,8440,9056 PROGRAMMING

No Press once, or twice for 7300, until the screen displays:

READ/MODIFY COPY SOCKET DATA

YES Press and the screen displays:

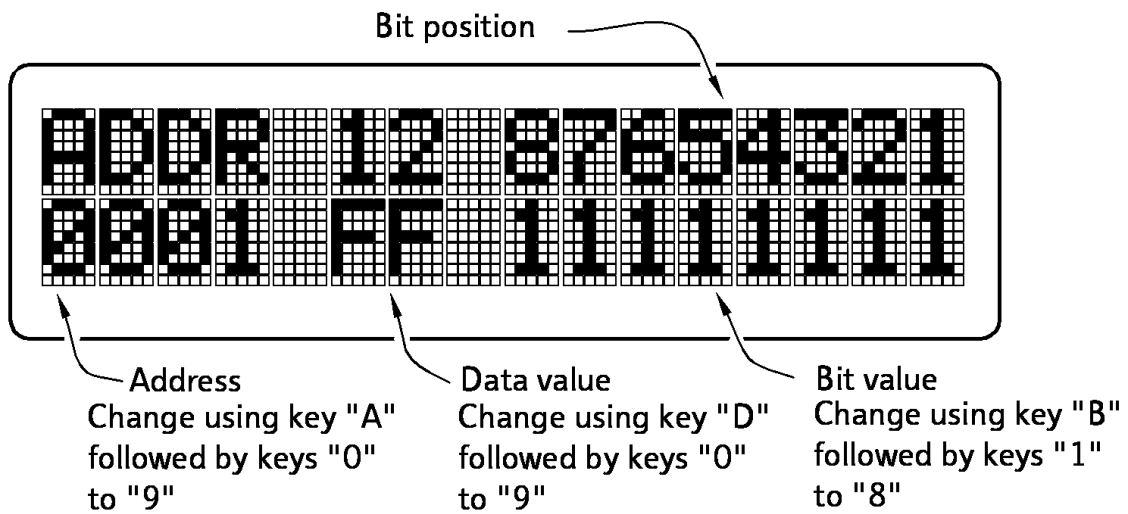

Press in sequence: The address display changes to:

0 0 3 2	
If the Control Relay is to be energised on power up press	<input type="button" value="1"/>
If the Control Relay is to be not energised on power up press	<input type="button" value="0"/>

If the Line Fault Relay is to be energised on fault, press	<input type="button" value="1"/>
If it is to be not energised , press	<input type="button" value="0"/>
Line Fault Relay not energised and output signal on SK2 pin 15 inverted, press.....	<input type="button" value="2"/>
Line Fault Relay energised and output signal On SK2 pin 15 inverted, press.....	<input type="button" value="3"/>
Line Fault Relay not energised and output signal Comms Fail on SK1 pin 7 inverted, press.....	<input type="button" value="4"/>
Line Fault Relay energised and output signal Comms Fail on SK1 pin 7 inverted, press.....	<input type="button" value="5"/>
Line Fault Relay not energised and both output signals inverted, press.....	<input type="button" value="6"/>
Line Fault Relay energised and both output signals inverted, press.....	<input type="button" value="7"/>

or
or
or
or
or
or
or
or

Press....  to advance the address display to:

0 0 3 3

If the **Telephone Line Type** is **PSTN** press  or

If it is a **private wire** press 

(Different key presses may be required to overcome certain equipment compatibility problems: see page 37.)

For normal **Line Monitoring** mode press  or

For **Earth Calling** mode press 

Press.....  to advance the address display to:

0 0 3 4

Press 

Press 

(This disables serial data, and enables GSM operation)

Press in sequence: The address display changes to:

0 0 3 5	
Use keys	<input type="button" value="1"/> to <input type="button" value="4"/> to set the bits required for the options detailed:
00000000	Line fail asserted when both paths fail.
00000001	Line fail asserted when either path fails.
00000010	Line fail asserted when landline path fails.
00000011	Line fail operates in accordance with BSIA specification.
00000110	Line fail asserted when landline path fails and RPS relay operates when GSM path fails.
00001010	Line fail asserted when landline path fails and Control Relay operates when GSM path fails.

Press in sequence: The address display changes to:

0 0 4 7	
Key in the first two digits of the hard ID , press yes and key in the final two digits. For example, a hard ID of 0567 would be entered:	
<input type="button" value="0"/> <input type="button" value="5"/> <input type="button" value="YES"/> <input type="button" value="6"/> <input type="button" value="7"/>	
To maintain the highest level of security, the hard ID should be unique for each STU.	

Press in sequence: The address display changes to:

0 0 6 0

Use keys to to set the **polarity of alarm pins 1 to 8**.

Pressing the numbered key changes the setting of the polarity from 0 to 1, or 1 to 0. A state of **1** means **positive applied** and a state of **0** means **positive removed**.

Press..... to advance the address display to:

0 0 6 1

Use keys

to change the **polarity of alarm pins 9, 10, 11, T and F** respectively.

A state of **1** means **positive applied** and a state of **0** means **positive removed**.

Press in sequence: The address display changes to:

0 0 6 6

Use keys to to select the pins that are **opening/closing channels**. A state of **1** means that the alarm pin is an **opening/closing channel** a state of **0** means that it is **not an opening/closing channel**.

Press..... to advance the address display to:

0067

Use the keys to designate alarm

pins 9, 10 and 11 respectively to be **opening and closing channels**. A state of **1** means that alarm pin is an **opening/closing channel** a state of **0** means that it is **not an opening/closing channel**.

Press in sequence:

The address display changes to:

0070

Use keys to to designate **alarm pins that are enabled**.

A state of **1** means the pin is **enabled** and a state of **0** means the pin is **disabled**.

Press.....

to advance the address display to:

0071

Use keys to designate

whether alarm pins 9, 10, 11, T and F respectively are **enabled**. A state of **1** means the pin is **enabled** and a state of **0** means the pin is **disabled**.

The NVM is now completely programmed. Set the power switch to 0, remove the programmed NVM and insert it in the **GSM STU EV** at position IC10 (see page 20).

STATUS INDICATORS

The status indicators are to be found in two distinct groups:

STU Status Indicators:

Three LEDs in the bottom
Left corner of the circuit board

GSM Status Indicators:

Four LEDs in the top left
corner of the circuit board.

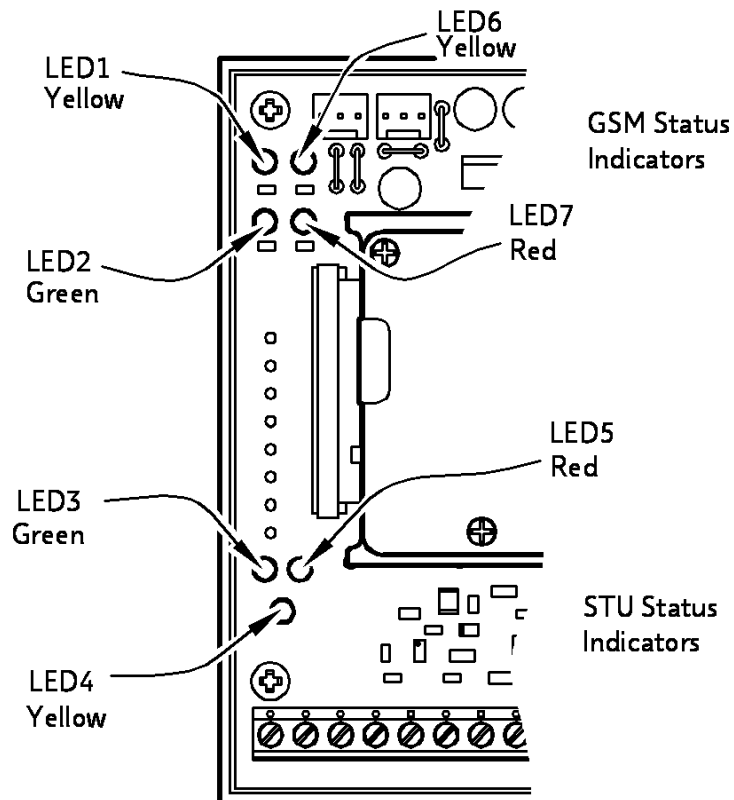

LED	Indication	Normal state
1 (yellow)	GSM Signal Strength 1	On
6 (yellow)	GSM Signal Strength 2	On
2 (green)	GSM Transceiver OK	Flashing every 2 s
7 (red)	GSM Status	Off
3 (green)	STU Status 1	Intermittent flash
5 (red)	STU Status 2	Off
4 (yellow)	Warning	Off

Key to LED flash rates:

Slow

About $2\frac{1}{2}$ s on, $2\frac{1}{2}$ s off.

Medium

About $1\frac{1}{4}$ s on, $1\frac{1}{4}$ s off.

Fast

About $\frac{1}{3}$ s on, $\frac{1}{3}$ s off.

Flutter

About 12 flashes per second.

Intermittent

One or more flashes about $\frac{1}{3}$ s on and then off for more than $2\frac{1}{2}$ s.

STU Status LED Meanings

The STU status is indicated on the LEDs in priority order - highest first. Where a high priority condition exists, it is indicated on the LED and suppresses the indication of lower priority conditions.

For example, if a battery low condition is present, battery low is indicated on the red LED regardless of the state of AC Fail.

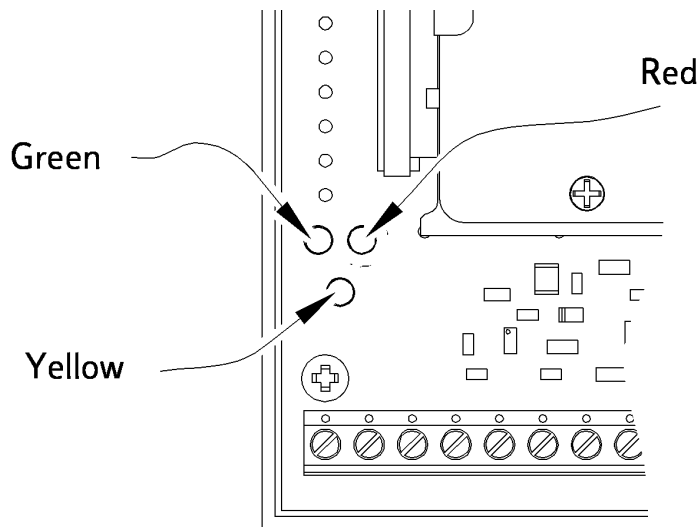

Green flutter flash for $\frac{2}{3}$ s:

Transmitting or receiving alarm data over landline.

Green fast flash:

Landline has failed (GSM signalling starts)

Green intermittent flash:

Landline is up and **GSM STU EV** commissioned.

Green slow flash:

The **GSM STU EV** has not been commissioned by the ARC.

Green permanently off:

GSM STU EV is not powered.

Red permanently off:

Normal

Red fast flash:

Battery power is low. Battery low is indicated on the LED as soon as it is detected. The battery low alarm is only transmitted after a delay.

Red slow flash:

Mains power supply failed. AC Fail is indicated on the LED as soon as it is detected. The AC Fail alarm is only transmitted after ten to twenty minutes. AC Fail alarm input (pin F) must be enabled in the NVM and the signal from the power supply wired to the terminal marked "F" on terminal block TB1.

Red flutter flash:

The **GSM STU EV** has detected an NVM configuration error.

Yellow off:

Normal

Yellow flutter flash:

STU is learning pin alarm polarities.

Yellow fast flash:

The NVM chip has been changed (or installed for the first time).

Yellow medium flash:

The **GSM STU EV** is in Security Mode. While the GSM STU EV is in Security Mode, it will indicate Line Fault OK on both the plug-in connector (SK2 pin 15) output and on the Line Fault relay. Security Mode will be cancelled if the GSM STU EV is reset (i.e. power cycled), or if it is upped on the landline, or after 20 minutes. If necessary, Security Mode can be re-enabled after upping to indicate Line Fault OK for another 20 minutes. This feature solves the problem of "Line Fault" being displayed by certain alarm panels before the GSM STU EV is commissioned.

Yellow intermittent flash:

GSM STU EV has one or more alarms or openings/closings present.

Alarms counted include alarm pins 1 to 11 only. The LED flashes once for each unacknowledged alarm on pins 1 to 11 and is then off for a few seconds. A pin 8 alarm will be triggered by a GSM failure. The alarm count does not include the mains fail alarm

GSM LED Meanings:

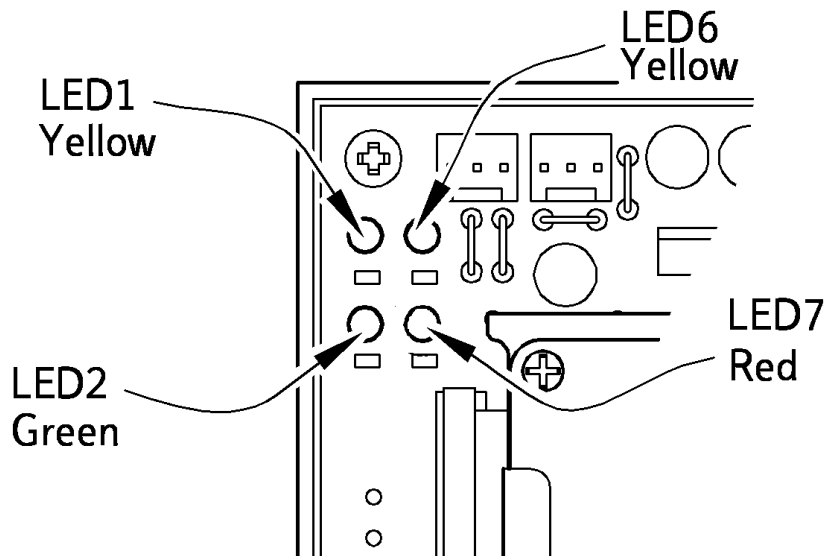

Yellow:

These two LEDs indicate the GSM radio signal strength. The signal strength is adequate when **both** are illuminated. If they do not light when the unit is in operation the signal strength is too low and the **GSM STU EV** will send a PIN 8 alarm over the PSTN.

If only LED1 is lit, signal strength is low and may be improved by fitting an extension antenna or re-siting the unit.

Yellow flutter flash:

GSM message received.

Green permanently on or permanently off:

GSM unit failed.

Green flashing every 2 s:

GSM unit working.

Red off:

GSM unit enabled (normal)

Red flutter flash:

The GSM unit has detected a fault with the SIM card in the GSM module.

Red slow flash:

Not commissioned.

Red medium flash:

Not initialised.

Red fast flash:

GSM network problem.

Red permanently on:

GSM module failed.

SYSTEM COMMISSIONING

Note 1: The **GSM STU EV** should not be commissioned if a data device is busy using the telephone line.

Note 2: If an MCD is fitted it will disconnect the telephone or data device connected through it during commissioning.

Apply power to the alarm panel and the **GSM STU EV** and observe the STU Status indicators. The green STU Status LED will slow flash (on for 2.5 seconds approx. and off for 2.5 seconds approx.).

Similarly, the GSM Status LEDs should be observed. When power is applied the GSM Status red LED should fast flash. This indicates that the GSM unit is being initialised which will take one to two minutes. When the initialisation sequence is complete, at least one of the two GSM Status yellow LEDs should illuminate and the GSM Status red LED will then slow flash. The **GSM STU EV** is now ready to be commissioned.

During the commissioning procedure, the STU is "upped" on the landline and the GSM signalling path is enabled. The GSM enabling sequence is started simultaneously to the landline upping procedure, but takes longer. Call the ARC, preferably using the same line as the **GSM STU EV**, and ask them to commission the system ("Up the STU").

During this process the GSM status LEDs will flutter flash when any of the seven commissioning messages are transmitted or received. When the GSM signalling path is fully enabled the GSM Status red LED will go out completely.

The green STU Status LED will give a short flutter each time a landline message, heard as a "chirp", is sent or received.

When the ARC confirms that the system is commissioned the green STU Status LED should flash every 5 seconds. The yellow STU Status LED may either be off, or produce short flashes every 10 seconds. The short flashes indicate the number of alarms triggered.

If, during the commissioning procedure, power to the **GSM STU EV** is interrupted, even momentarily, the above procedure will have to be repeated.

Testing the System

Once the **GSM STU EV** has been commissioned, all of the used alarm inputs and relay outputs should be tested. To test the alarm inputs you must be in contact with the ARC.

Each alarm should be tested in the following manner:

- a) Trigger the alarm (the yellow STU Status LED4 should give **one** quick flash every 10 seconds signifying **one** alarm has been triggered).
- b) Ask the ARC to confirm that it has received the alarm message.
- c) Ask the ARC to acknowledge the alarm.

- d) Remove the alarm trigger (the yellow STU Status LED4 should stop flashing).
- e) Ask the ARC to confirm that it has received the reset message.
- f) Ask the ARC to acknowledge the reset.

If personal attack buttons form part of the system they must be tested as above.

If used, the Control Output should be tested as follows:

- a) Ask the ARC to turn on the Control Output.
- b) Confirm that Control Output is activated (e.g. Remote Reset).
- c) Ask the ARC to turn off the Control Output.
- d) Confirm that the Control Output is deactivated.

If used, the RPS output should be tested as follows:

- a) Trigger the alarm which has been designated as the opening/closing channel.
- b) Confirm that the RPS warning device is activated and ask the ARC to confirm that it has received the opening message.
- c) Ask the ARC to acknowledge the opening.
- d) Confirm that the RPS warning device is de-activated.

The GSM backup system should be tested as follows:

- a) Disconnect the **GSM STU EV** from the telephone line.
- b) Confirm that the STU status green LED3 changes to fast flash after 30 to 90s.
- c) Trigger an alarm and confirm that the ARC receives the alarm.
- d) Reconnect the telephone line.

The Line Fault output should be tested as follows:

- e) Disconnect the **GSM STU EV** from the telephone line.
- f) Confirm that the Line Fault relay activates.
- g) Replace the telephone line connection and ensure that the relay de-activates.
- h) Carefully disconnect the antenna cable from the GSM module.
- i) Confirm that the Line Fault relay activates within 210 seconds.
- j) Reconnect the antenna and verify that the Line Fault relay is de-activated.

Note: The Line Fault relay test may not be 100% reliable as there may be enough signal to enable GSM communications even without the antenna attached. (Observe the signal strength LEDs).

When all of the above tests have been successfully completed, all the alarm triggers should be removed and the Alarm Receiving Centre asked to acknowledge all of the unacknowledged alarms. The **GSM STU EV** red LED5 should be off and the green LED3 should produce a short flash every 5 seconds. This signifies that the **GSM STU EV** is commissioned and there are no outstanding alarms.

Affix the **redcare gsm** sticker to the outside of the box containing the **GSM STU EV**: this will indicate that the GSM device is active inside.



Warranty

The warranty covers defects in materials and workmanship. The warranty is invalidated by misuse or neglect by the customer and defects caused by improper installation or operating practices. Damage such as that caused by lightning or inadequate return packaging will also void the warranty. In no event shall **BT redcare** be liable for any consequential damage.

Repairs

Faulty **GSM STU EVs** must be returned to **BT redcare** for repair.

All non-warranty repairs are charged at a standard fixed price plus a shipping charge and VAT.

TROUBLESHOOTING

This section describes typical problems that may arise, the symptoms, possible causes and solutions. If you have problems that you cannot resolve after consulting this section, please contact **redcare** Technical Helpline Freephone: 0800 671 240

Chirps

The **redcare** system utilises an existing telephone line to provide a secure communications link between the alarm system at the protected premises and the ARC.

To facilitate this, two modes of communication are employed: a continuous inaudible low-tone, normally present all the time, and an audible 'chirp', used to transmit alarm messages and check for the presence of the STU.

These 'chirps' will not normally be heard, but they can occasionally occur as the telephone handset is lifted. This 'chirp' should be heard only once. If 'chirps' are heard regularly during conversation, please contact **BT redcare** for advice.

Substitution

BT redcare maintain a database of the unique CPE numbers matched to the associated PSTN telephone number and the mobile phone number of the GSM unit. For this reason the SIM card in the GSM unit cannot be changed or used in any other installation. If a **GSM STU EV** is suspected of being faulty, it is not possible to substitute the unit for a different one without the help of **BT redcare**.

Equipment Compatibility Issues

Certain compatibility issues with specific equipment can be overcome by changing the low-tone signalling level output from the STU. Only where advised by **BT redcare**, the low-tone attenuation setting can be changed by re-programming the NVM. The NVM address concerned is number 33 which also contains the line monitoring mode setting. The options available are shown on page 38.

Line Type	Earth Calling Line	On Hook Atten.	Off Hook Atten.	Data Value at Address 33	Bit Value
PSTN	No	0 dB	0 dB	21	00100001
PSTN	No	0 dB	-3 dB	01	00000001
PSTN	No	0 dB	-6 dB	31	00110001
PSTN	No	0 dB	-9 dB	41	01000001
PSTN	No	-3 dB	-3 dB	51	01010001
PSTN	No	-3 dB	-6 dB	61	01100001
PSTN	No	-3 dB	-9 dB	71	01110001
PSTN	No	-6 dB	-6 dB	81	10000001
PSTN	No	-6 dB	-9 dB	91	10010001
PSTN	No	-9 dB	-9 dB	A1	10100001
PSTN	Yes	0 dB	0 dB	22	00100010
PSTN	Yes	0 dB	-3 dB	02	00000010
PSTN	Yes	0 dB	-6 dB	32	00110010
PSTN	Yes	0 dB	-9 dB	42	01000010
PSTN	Yes	-3 dB	-3 dB	52	01010010
PSTN	Yes	-3 dB	-6 dB	62	01100010
PSTN	Yes	-3 dB	-9 dB	72	01110010
PSTN	Yes	-6 dB	-6 dB	82	10000010
PSTN	Yes	-6 dB	-9 dB	92	10010010
PSTN	Yes	-9 dB	-9 dB	A2	10100010
PW	n/a	0 dB	0 dB	11	00010001
PW	n/a	0 dB	0 dB	12	00010010
PW	n/a	-3 dB	-3 dB	D1	11010001
PW	n/a	-3 dB	-3 dB	D2	11010010
PW	n/a	-6 dB	-6 dB	E1	11100001
PW	n/a	-6 dB	-6 dB	E2	11100010
PW	n/a	-9 dB	-9 dB	F1	11110001
PW	n/a	-9 dB	-9 dB	F2	11110010

Symptom	Possible Causes	Possible Solution
Problems indicated on the STU Status LEDs		
Yellow STU Status LED4 Fast flash.	a) NVM not fitted. b) NVM unprogrammed. c) NVM wrong way around. d) NVM leg bent under. e) The NVM has been removed from the STU. f) NVM fitted for the first time.	a), b), c) Insert correctly programmed NVM. d) Refit NVM. e) Power down, insert the NVM and re-apply power to the GSM STU EV . Ask the ARC to commission the STU again. f) Configure the STU to use the plug-in NVM (see page 23).
When an alarm is triggered the number of outstanding alarms does NOT increase. The yellow STU Status LED4 is off or the number of flashes of the yellow LED stays the same. The green STU Status LED3 intermittent flash.	a) An alarm previously transmitted on the same channel has not been acknowledged by the ARC. b) The NVM has been incorrectly programmed and the alarm channel has been disabled by mistake.	a) Ask the ARC to acknowledge any outstanding alarms. b) Re-program the NVM.
The Yellow STU Status LED4 flashes up to eleven times after every other flash of the green STU Status LED3.	Each yellow LED flash represents an outstanding alarm. a) Alarm input/s may be incorrectly wired. b) Alarm information may be programmed incorrectly in the NVM.	a) Check/correct the alarm input wiring. b) i) Re-configure alarm settings. ii) Re-program the NVM iii) Use the "LEARN" polarity procedure.

Symptom	Possible Causes	Possible Solution
Red STU Status LED5 fast flash.	Power supply and/or battery voltage to the GSM STU EV is too low.	Check the operation of the power supply. Check that the back up battery is charged.
Red STU Status LED5 flutter flash.	NVM program error.	GSM disabled in NVM, in this case, it may still be possible to up the GSM STU EV on the landline only. Re-program the NVM.
Red STU Status LED5 slow flash, but mains is present on power supply.	AC fail alarm in NVM or EEPROM wrong polarity.	i) Re-program the NVM. ii) Use the "LEARN" polarity procedure.
ARC cannot commission the GSM STU EV , and the phone line is otherwise OK. Green STU Status LED3 slow flash.	a) GSM STU EV is not enabled by BT Red. b) Wrong phone line being used. c) Wrong GSM STU EV commissioned by the ARC.	a), b), c) Seek assistance from the ARC.
ARC is reporting NO RESPONSE and chirps can be heard on the phone line. Green STU Status LED3 slow flash.	There has been a momentary power failure in the control panel.	Ask the ARC to commission the STU again.
ARC is reporting NO RESPONSE and chirps CANNOT be heard on the phone line. (Green STU Status LED3 fast flash.)	There is a failure of the phone line.	Report the failure to your local BT fault repair service. Phone 151 for residential customers. Phone 154 for business and RedDIRECT customers.
Problems indicated on the GSM Status LEDs		
Red GSM Status LED7 fluttering.	The SIM card may be damaged, wrong or missing.	Contact redcare Helpdesk for assistance.

Symptom	Possible Causes	Possible Solution
Green GSM Status LED2 permanently on.	The GSM unit has failed to initialise.	Power cycle the GSM STU EV and try to commission it again.
No GSM signal strength LEDs are illuminated.	a) The antenna may be disconnected or the signal is being blocked. b) The SIM card may not be enabled onto the GSM network.	a) i) Check antenna connection. ii) Use extension antenna. iii) Remove local obstruction from around antenna. b) Contact redcare Helpdesk for assistance.
Problems NOT indicated by the LEDs		
The alarm panel is in a permanent local line fault condition.	The line fault output has been programmed to the wrong polarity.	Re-program the NVM.
Regular 'chirps' are heard (every 2 minutes) whenever the telephone is in use	PABX or telephone compatibility problems	Report make and model details to redcare Helpdesk and ask for advice.
The ARC is reporting the receipt of a channel 12 alarm but tamper pin is not active.	a) This is an internal alarm generated by the STU to indicate a tamper condition. b) The NVM has been removed from a commissioned STU. c) Tamper pin set to the wrong polarity in the NVM	Re-program the NVM.
The ARC is reporting the receipt of a channel 14 alarm.	This is an internal alarm generated by the STU to indicate a battery low condition.	Possible mains failure or faulty battery.
No activity on the GSM STU EV , no LEDs on.	The power is off.	Check for 12V dc at TB1 V+ with respect to TB1 0V

Symptom	Possible Causes	Possible Solution
Regular 'chirps' are heard (every 2½ to 3 minutes) whenever the telephone is in use.	The NVM has been programmed for Private Wire mode and the STU is connected to a normal phone line (PSTN).	Re-program the NVM for 'PSTN mode'.
Calls cannot be made from the GSM STU EV phone line.	<ul style="list-style-type: none"> a) LK1 fitted when STU is connected to the PSTN. b) Incorrect phone line wiring to the STU. c) Faulty wiring at the redcare block terminal. d) Faulty phone line. 	<ul style="list-style-type: none"> a) Remove LK1. b) Check and correct the wiring. c) Seek assistance from the ARC. d) Report the fault to your local BT fault repair service.
The ARC is reporting the receipt of a channel 15 alarm.	This is an internal alarm generated by the STU to indicate a self test failure.	The STU has detected a fault in its internal circuitry. Replace the STU.

DISPOSAL



The symbol shown here and on the product, means that the product is classed as Electrical or Electronic Equipment and should not be disposed of with other household or commercial waste at the end of its working life.

 The Waste Electrical and Electronic Equipment (WEEE) Directive (2002/96/EC) has been put in place to recycle products using the best available recovery and recycling techniques to minimise the impact on the environment, treat any hazardous substances and avoid the increasing landfill.

Product disposal instructions for residential users:

When you have no further use for it, please dispose of the product as per your local authority's recycling processes. For more information please contact your local authority or retailer where the product was purchased.

Product disposal instructions for business users:

Business users should return the product to the freepost address below:

Freepost RLXS-ETYY-ELCU
Rebound Electronics UK Ltd.
Basingstoke
Hants
RG24 8FL

Only return the product sub assembly (not the complete alarm panel) to BT redcare for recycling.



**POLICE PREFERRED
SPECIFICATION**



Offices worldwide

The telecommunications services described in this publication are subject to availability and may be modified from time to time. Services and equipment are provided subject to British Telecommunications plc's respective standard conditions of contract. Nothing in this publication forms any part of any contract.

© 2003 British Telecommunications plc.
Registered office: 81 Newgate Street, London EC1A 7AJ
Registered in England No: 18000000
Produced in England
Please quote ref: 47525 Iss E when reordering copies of this document.
Please print on paper which meets international environmental standards.